



Coimisiún na Scrúduithe Stáit
State Examinations Commission

JUNIOR CERTIFICATE 2008

MARKING SCHEME

MATHEMATICS

ORDINARY LEVEL

PAPER 1

GENERAL GUIDELINES FOR EXAMINERS

1. Penalties of three types are applied to candidates' work as follows:
 - Blunders - mathematical errors/omissions (-3)
 - Slips- numerical errors (-1)
 - Misreadings (provided task is not oversimplified) (-1).

Frequently occurring errors to which these penalties must be applied are listed in the scheme. They are labelled: B1, B2, B3,..., S1, S2,..., M1, M2,... etc. These lists are not exhaustive.

2. When awarding attempt marks, e.g. Att(3), note that
 - any *correct, relevant* step in a part of a question merits at least the attempt mark for that part
 - if deductions result in a mark which is lower than the attempt mark, then the attempt mark must be awarded
 - a mark between zero and the attempt mark is never awarded.
3. Worthless work is awarded zero marks. Some examples of such work are listed in the scheme and they are labelled as W1, W2,...etc.
4. The phrase “hit or miss” means that partial marks are not awarded – the candidate receives all of the relevant marks or none.
5. The phrase “and stops” means that no more work is shown by the candidate.
6. Special notes relating to the marking of a particular part of a question are indicated by an asterisk. These notes immediately follow the box containing the relevant solution.
7. The sample solutions for each question are not intended to be exhaustive lists – there may be other correct solutions.
8. Unless otherwise indicated in the scheme, accept the best of two or more attempts – even when attempts have been cancelled.
9. The *same* error in the *same* section of a question is penalised *once* only.
10. Particular cases, verifications and answers derived from diagrams (unless requested) qualify for attempt marks at most.
11. A serious blunder, omission or misreading results in the attempt mark at most.
12. Do not penalise the use of a comma for a decimal point, e.g. €5.50 may be written as €5,50.

QUESTION 1

Part (a)	10(5, 5) marks	Att 4(2, 2)
Part (b)	20 (5, 5, 5, 5) marks	Att 8 (2, 2, 2, 2)
Part (c)	20 (5, 5, 5, 5) marks	Att 8 (2, 2, 2, 2)

Part (a) (i) **5 marks** **Att 2**

$S = \{a, b, c\}$

1(a) (i) Write down a subset of S that has one element

Part (a) (i) **5 marks** **Att 2**

$\{a\}$ or $\{b\}$ or $\{c\}$.

- * No penalty for the omission of brackets.
- * No penalty for use of Venn Diagram to show subsets.

Blunders (-3)

B1 Any incorrect set of elements of S other than the misreading below.

Misreadings (-1)

M1 Subset of S with two elements. e.g. $S = \{a, b\}$.

Attempts (2 marks)

A1 Draws a single bracket & stops.

A2 $\{ \}$ Null set.

Part (a) (ii) **5 marks** **Att 2**

$S = \{a, b, c\}$

1(a) (ii) Write down a subset of S that has two elements

Part (a) (ii) **5 marks** **Att 2**

$\{a,b\}$ or $\{a,c\}$ or $\{b,c\}$

- * No penalty for omission of brackets.
- * No penalty for use of Venn Diagram to show subsets.

Blunders (-3)

B1 Any incorrect set of elements of S other than the misreading below.

Misreadings (-1)

M1 Subset of S with one element. e.g. $S = \{a\}$.

Attempts (2)

A1 Draws a single bracket & stops.

A2 $\{ \}$ Null set.

Part (b)

20 (5, 5, 5, 5)

Att 8 (2,2,2,2)

1(b)

U is the universal set.

$$P = \{2, 3, 6, 7, 8\}$$

$$Q = \{1, 6, 8, 10\}$$

$$R = \{2, 4, 6\}$$

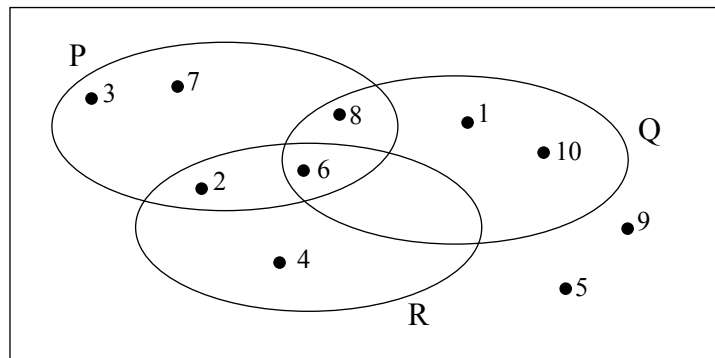

Part (b) (i)

5 marks

Att 2

1 (b) (i) List the elements of: $P \cap Q$

Part (b) (i)

5 marks

Att 2

$$P \cap Q = \{6, 8\}$$

Blunders (-3)

B1 Any incorrect set of elements of P and Q other than the misreading below.

Misreadings (-1)

$$M1 \quad P \cup Q = \{1, 2, 3, 6, 7, 8, 10\}.$$

Attempts (2 marks)

A1 4 or 5 or 9 appear in the answer.

Part (b) (ii)

5 marks

Att 2

1 (b) (ii) List the elements of: $Q \setminus R$

Part (b) (ii)

5 marks

Att 2

$$Q \setminus R = \{1, 8, 10\}$$

Blunders (-3)

B1 Any incorrect set of elements of Q and R other than the misreading below.

Misreadings (-1)

$$M1 \quad R \setminus Q = \{2, 4\}.$$

Attempts (2 marks)

A1 3 or 5 or 7 or 9 appear in the answer.

Part (b) (iii)

5 marks

Att 2

1 (b) (iii) List the elements of: $(Q \cup R)'$

Part (b) (iii)

5 marks

Att 2

$$(Q \cup R)' = \{3, 5, 7, 9\}$$

Blunders (-3)

B1 Any incorrect set of elements of Q and R other than the misreadings below.

B2 $(Q \cup R) = \{1, 2, 4, 6, 8, 10\}$

Misreadings (-1)

M1 $(Q \cap R)' = \{1, 2, 3, 4, 5, 7, 8, 9, 10\}$

M2 $Q' \cup R' = \{1, 2, 3, 4, 5, 7, 8, 9, 10\}$

Attempts (2 marks)

A1 Any incorrect listing of element(s) other than the misreadings above.

Part (b) (iv)

5 marks

Att 2

1 (b) (iv) List the elements of: $(P \cap R) \setminus Q$

Part (b) (iv)

5 marks

Att 2

$$(P \cap R) \setminus Q = \{2\}$$

Blunders (-3)

B1 Any incorrect set of elements of P and Q and R other than the misreadings below.

B2 $P \cap R = \{2, 6\}$

Misreadings (-1)

M1 $Q \setminus (P \cap R) = \{1, 8, 10\}$.

M2 $(P \cup R) \setminus Q = \{2, 3, 4, 7\}$

Attempts (2 marks)

A1 5 or 9 appear in the answer.

Part(c)

20(5, 5, 5, 5)

Att 8 (2, 2, 2, 2)

M is the set of natural numbers from 1 to 36, inclusive

Part (c) (i)

5 marks

Att 2

1(c) (i) List the elements of M that are multiples of 6.

Part (c) (i)

5 marks

Att 2

6, 12, 18, 24, 30, 36.

Slips (-1)

S1 Each missing or incorrect element subject to a max of 3.

Attempts (2 marks)

A1 Any one correct element identified.

A2 Any correct factor(s) of 6.

Worthless (0)

W1 Elements listed are not multiples or factors of 6.

Part (c) (ii)

5 marks

Att 2

1(c) (ii) List the elements of M that are multiples of 9.

Part (c) (ii)

5 marks

Att 2

9, 18, 27, 36.

Slips (-1)

S1 Each missing or incorrect element subject to a max of 3.

Attempts (2 marks)

A1 Any one correct element identified.

A2 Any correct factor(s) of 9.

Worthless (0)

W1 Elements listed are not multiples or factors of 9.

Part (c) (iii) **5 marks** **Att 2**

1(c) (iii) Write down the lowest common multiple of 6 and 9.

- * Accept candidate's L.C.M. from incorrect answers in part (i) and part (ii) for full marks.
- * Accept indication of candidate's L.C.M.

Part (c) (iii) **5 marks** **Att 2**

L.C.M. = 18

Blunders (-3)

B1 An incorrect common multiple that is not the lowest.e.g. {36}.

Slips (-1)

S1 Answer written as $2 \times 3 \times 3$ and stops.

Misreadings (-1)

M1 Writes down H.C.F. = 3.

Attempts (2 marks)

A1 Any multiple of either 6, or 9 written in this part.

Worthless (0)

W1 Elements listed are not multiples of 6 or 9.

Part (c) (iv) **5 marks** **Att 2**

1(c) (iv) Express 30 as the product of three prime numbers,

Part (c) (iv) **5 marks** **Att 2**

$30 = 2 \times 3 \times 5$

- * 2, 3, 5, listed merits full marks.

Blunders (-3)

B1 Each correct prime constituent omitted and/or each incorrect prime constituent included.

Misreadings (-1)

M1 Write as sum of 3 primes ($30 = 2 + 5 + 23$) or ($30 = 2 + 11 + 17$).

Attempts (2 marks)

A1 Writes a prime number $\in M$.

Worthless (0)

W1 No prime number appears.

QUESTION 2

Part (a)	10 marks	Att 3
Part (b)	20 (5, 10, 5)	Att 7 (2, 3, 2)
Part (c)	20 (10, 5, 5)	Att7 (3, 2, 2)

Part (a) **10 marks** **Att 3**

2(a) €260 is shared between Mark and Una in the ratio 6:7.
How much does each receive?

Part (a) **10 marks** **Att 3**

<p>6 parts : 7parts</p> <p>13 Parts = 260</p> <p>$\Rightarrow 1 \text{ Part} = \frac{260}{13} = 20$</p> <p>Mark = $20 \times 6 = 120$</p> <p>Una = $20 \times 7 = 140$</p> <p><u>OR</u> $260 - 120 = 140$</p>	<p>$6x : 7x$</p> <p>$\Rightarrow 13x = 260$</p> <p>$\Rightarrow x = 20$</p> <p>$\Rightarrow 6x = 120$</p> <p>$\Rightarrow 7x = 140$</p>	<p>$6 + 7 = 13$</p> <p>$\frac{1}{13} = 20$</p> <p>$\Rightarrow \frac{6}{13} = 120$ (Mark)</p> <p>$\Rightarrow 260 - 120 = 140$ (Una)</p> <p><u>OR</u> $\frac{7}{13} = 140$</p> <p>$\Rightarrow 260 - 140 = 120$</p>
$260 - 140 = 120$		$\Rightarrow 260 - 140 = 120$

Blunders (-3)

- B1 Correct answers without work.
- B2 Divisor $\neq 13$ only and continues.
- B3 Incorrect multiplier or fails to multiply. (each time).
- B4 Error in transposition.
- B5 Fails to find second amount.
- B6 Adds instead of subtracts. e.g. $260 + 120 = 380$ or $260 + 140 = 400$.
- B7 Finds 6% of 260 ($15 \cdot 6$) and 7% of 260 ($18 \cdot 2$)

Slips (-1)

- S1 Numerical errors to a max of 3.

Misreadings (-1)

- M1 Interchanges Mark and Una.

Attempts (3 marks)

- A1 Divisor $\neq 13$ e.g. $\frac{260}{6}$ and/or $\frac{260}{7}$ and stops.
- A2 Indicates 6 parts or 7 parts or 13 parts or $\frac{6}{13}$ or $\frac{7}{13}$ or $6 + 7 = 13$ and stops.
- A3 Indicates multiplication of 260 by 6 and/or 7 and stops.
- A4 Both answers added together equal €260. (No work shown).

Worthless (0)

- W1 Incorrect answer without work. {Subject to A4}.

Part (b) (i)

5 marks

Att 2

2(b) (i) On a day when $\text{€}1 = \text{£}0.68$, find the value in euro of $\text{£}816$.

Part (b) (i)

5 marks

Att2

	
$\text{€}1 = \text{£}0.68$ $\text{€?} = \text{£}816$	$\text{£}0.68 = \text{€}1$ $\Rightarrow \text{£}1 = \text{€} \frac{1}{0.68} \quad \left(\frac{25}{17} \right)$
$? = \frac{816}{0.68} = \text{€}1200$	$\Rightarrow \text{£}816 = 816 \times \frac{1}{0.68} = \text{€}1200$

* No penalty for the omission of € or £ symbols.

* Note: Natural Display calculator gives $\left(\frac{1}{0.68} \right) = \left(\frac{25}{17} \right)$, $816 \times 0.68 = \left(\frac{13872}{25} \right)$.

Blunders (-3)

B1 Correct answer without work. 

B2 Incorrect operation. i.e. $816 \times 0.68 = 554.88$

B3 Incorrect ratio $\frac{0.68}{816}$ or $\frac{68}{81600}$.

B4 Decimal error.

B5 Fails to finish, leaves as $\frac{816}{0.68}$ and stops.

Slips (-1)

S1 Numerical errors to a max of 3.

S2 Rounds off too early. e.g. $\frac{1}{0.68} = 1.470588235 = 1.47 (\text{€}1199.52)$ or $1.5 (\text{€}1224)$

Attempts (2 marks)

A1 $\text{£}1 = \text{€} \frac{1}{0.68}$ and stops.

Worthless (0)

W1 Adds or subtracts 816 to 0.68 and stops.

W2 Incorrect answer without work.

Part (b) (ii)

10 marks

Att 3

2(b) (ii) By rounding each of these numbers to the nearest whole number,
estimate the value of $\frac{5 \cdot 8 \times 8 \cdot 148}{11 \cdot 64}$.

Part (b) (ii)

10 marks

Att 3

 $\frac{5 \cdot 8 \times 8 \cdot 148}{11 \cdot 64}$ is approximately equal to

$$\frac{\boxed{6} \times \boxed{8} \quad \boxed{48}}{\boxed{12}} = \frac{\boxed{48}}{\boxed{12}} = \boxed{4}$$

- * $\frac{6 \times 8}{12}$ and stops \Rightarrow **4** marks.
- * No penalty if the intermediate step between approximations and final answer is not shown. i.e. $\frac{48}{12}$ not shown.
- * Special Case: $\frac{5 \cdot 8 \times 8 \cdot 148}{11 \cdot 64} = 4 \cdot 06 \cdot \left(\frac{203}{50}\right)$ presented in this part \Rightarrow Attempt **3** marks.

Blunders (-3)

- B1 Correct answer without work. 
- B2 Error(s) in rounding off to the nearest whole number. (once only)
- B3 Decimal error in calculation of final value.
- B4 An arithmetic operation other than indicated.
- B5 Error(s) in the manipulation of the denominator. e.g. $\frac{6}{12} \times \frac{8}{12} = \frac{48}{144}$.
- B6 Incorrect cancellation e.g. $\frac{6 \times 8}{12} = \frac{3 \times 4}{6} = \frac{12}{6} = 2$

Slips (-1)

- S1 Numerical errors to a max of 3.

Attempts (3 marks)

- A1 Only one or two approximations made to the given numbers and stops.

Worthless (0)

- W1 Incorrect answer without work.

Part (b) (iii)

5 marks

Att 2

2(b) (iii) Using a calculator, or otherwise, find the exact value of $\frac{5 \cdot 8 \times 8 \cdot 148}{11 \cdot 64}$.

Part (b) (iii)

5 marks

Att 2

$$\frac{5 \cdot 8 \times 8 \cdot 148}{11 \cdot 64} = \frac{47 \cdot 2584}{11 \cdot 64} = 4 \cdot 06 \left(\frac{203}{50} \right) \left(4 \frac{3}{50} \right)$$

* Note: $\left(\frac{5 \cdot 8}{11 \cdot 64} \right) = \frac{145}{291}$, $\left(\frac{8 \cdot 148}{11 \cdot 64} \right) = \frac{7}{10}$.

Blunders (-3)

B1 Decimal error.

B2 Leaves answer as $\frac{47 \cdot 2584}{11 \cdot 64}$.

B3 Treats as $\frac{5 \cdot 8}{11 \cdot 64} \times \frac{8 \cdot 148}{11 \cdot 64} = 0 \cdot 4982817869 \times 0 \cdot 7 = 0 \cdot 3487972509 \cdot \left(\frac{203}{582} \right)$.

B4 Reads as $\frac{5 \cdot 8 + 8 \cdot 148}{11 \cdot 64} = \frac{13 \cdot 948}{11 \cdot 64} = 1 \cdot 198281787 \cdot \left(\frac{3487}{2910} \right)$.

B5 Reads as $\frac{5 \cdot 8 - 8 \cdot 148}{11 \cdot 64} = \frac{-2 \cdot 348}{11 \cdot 64} = -0 \cdot 2017182131 \cdot \left(\frac{-587}{2910} \right)$.

B6 Treats as $\frac{11 \cdot 64}{5 \cdot 8 \times 8 \cdot 148} = \frac{11 \cdot 64}{47 \cdot 2584} = 0 \cdot 2463054187 \cdot \left(\frac{50}{203} \right)$.

B7 Treats as $\frac{11 \cdot 64}{5 \cdot 8 + 8 \cdot 148} = \frac{11 \cdot 64}{13 \cdot 948} = 0 \cdot 8345282478 \cdot \left(\frac{2910}{3487} \right)$.

B8 Treats as $\frac{11 \cdot 64}{5 \cdot 8 - 8 \cdot 148} = \frac{11 \cdot 64}{-2 \cdot 348} = -4 \cdot 957410562 \cdot \left(\frac{-2910}{587} \right)$.

Slips (-1)

S1 Numerical errors to a max of 3.

S2 Any rounding off.

Attempts (2 marks)

A1 Any correct relevant calculation and stops.

e.g. $5 \cdot 8 \times 8 \cdot 148 = 47 \cdot 2584$, $\left(\frac{5 \cdot 8}{11 \cdot 64} \right) = \frac{145}{291} = 0 \cdot 4982817869$, $\left(\frac{8 \cdot 148}{11 \cdot 64} \right) = \frac{7}{10} = 0 \cdot 7$.

Worthless (0)

W1 Incorrect answer without work.

Part(c) (i)

10 marks

Att 3

2(c) (i) Using a calculator, or otherwise, write $\frac{1}{5}$ and $\frac{11}{50}$ as decimals.

Hence, or otherwise, put the following numbers in order, starting with the smallest and finishing with the largest:

$$0.25, \frac{1}{5}, \frac{11}{50}$$

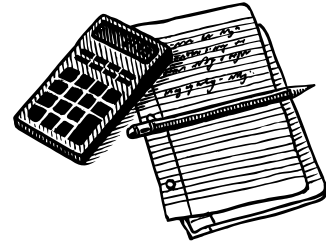

Part(c) (i)

10 marks

Att 3

$\frac{1}{5} = 0.2$		$\frac{11}{50} = 0.22$
$\frac{1}{5}$,	$\frac{11}{50}$,	0.25,

* Accept: 0.2, 0.22, 0.25, merits **10** marks.

* Accept: No penalty for writing 0.25 as $\frac{1}{4}$.

* Note: $\frac{1}{5} = 0.2$ or $\frac{11}{50} = 0.22$ merits **4** marks

Blunders (-3)

B1 Fails to write a fraction as a decimal.

B2 Writes fraction as incorrect decimal.

B3 Decimal error.

B4 Inverts fraction and continues.

B5 Incorrect order or fails to order.

Attempts (3 marks)

A1 $0.25 = \frac{1}{4}$ and stops.

Worthless(0)

W1 $\frac{0.25}{5}$, or $\frac{0.25}{50}$ or similar.

Part(c) (ii)

5 marks

Att 2

2(c) (ii)

Using a calculator, or otherwise, divide 1170 by 0.45 and express your answer in the form $a \times 10^n$, where $1 \leq a < 10$ and $n \in \mathbb{N}$

Part(c) (ii)

5 marks

Att 2



$$1170 \div 0.45 = 2600 = 2.6 \times 10^3$$

Blunders (-3)

B1 Correct answer without work. 

B2 Decimal error.

B3 Inverts $0.45 \div 1170 = 0.00038 \left(\frac{1}{2600} \right)$.

B4 Multiplies $1170 \times 0.45 = 526.5 = 5.256 \times 10^2 \left(\frac{1053}{2} \right)$.

Slips (-1)

S1 Numerical errors to a max of 3.

S2 Incorrect format, where $a < 1$ or $a \geq 10$ and $n \notin \mathbb{N}$.

S3 2600 and stops.

Attempts (2 marks)

A1 Any relevant step. e.g. Partial long division. e.g. $\frac{1170}{0.45} = 2$

A2 $\frac{1}{0.45} = \frac{20}{9}$

Part(c) (iii)

5 marks

Att 2

2(c) (iii) Using a calculator, or otherwise, evaluate

$$= (3 \cdot 9)^2 - \frac{5 \cdot 32}{\sqrt{0.64}} \times 1.81$$

Give your answer correct to two decimal places

Part(c) (iii)

5 marks

Att 2

~~✗~~

$$= 15 \cdot 21 - \frac{5 \cdot 32}{0.8} \times 1.81$$

$$= 15 \cdot 21 - 6 \cdot 65 \times 1.81$$

$$= 15 \cdot 21 - 12 \cdot 0365$$

$$= 3 \cdot 1735 \left(\frac{6347}{2000} \right)$$

$$= 3 \cdot 17$$

* Correct answer (without work) incorrectly rounded off \Rightarrow 2 marks.

e.g. $= 3 \cdot 1735, = 3 \cdot 174$

* Note: Natural Display calculator gives $(3 \cdot 9)^2 = \left(\frac{1521}{100} \right), \frac{5 \cdot 32}{\sqrt{0.64}} = \left(\frac{133}{20} \right),$

Blunders (-3)

B1 Correct answer without work. ~~✗~~

B2 Mishandles $(3 \cdot 9)^2$.

B3 Mishandles $\sqrt{0.64}$.

B4 Error in $5 \cdot 32 \div 0.8$ or $9 \cdot 6292 \div 0.8$.

B5 Error in $5 \cdot 32 \times 1.81$ or $6 \cdot 65 \times 1.81$.

B6 Decimal error.

B7 Subtracts before Division $(15 \cdot 21 - 5 \cdot 32) \div 0.8 \times 1.81 = 9 \cdot 89 \div 0.8 \times 1.81 = 22 \cdot 376125$.

B8 Subtracts before Multiplication $(15 \cdot 21 - 6 \cdot 65) \times 1.81 = 8 \cdot 56 \times 1.81 = 15 \cdot 4936$.

B9 Use of mathematical operator other than that which is indicated.

B10 Works as $15 \cdot 21 \times 1.81 - \frac{5 \cdot 32}{0.8} = 27 \cdot 5301 - 6 \cdot 65 = 20 \cdot 8801 = 20 \cdot 88$.

B11 Works as $\left(\frac{5 \cdot 32}{0.8} \times 1.81 \right) - 15 \cdot 21 = 12 \cdot 0365 - 15 \cdot 21 = -3 \cdot 1735 = -3 \cdot 17$.

Slips (-1)

S1 Numerical errors to a max of 3.

S2 Each premature rounding off that effects the final answer to a max of 3.

S3 Fails to round off or rounds off incorrectly when giving final answer.

S4 Leaves as $\frac{6347}{2000}$.

Attempts (2 marks.)

A1 Any correct relevant step e.g. $(3 \cdot 9)^2 = 15 \cdot 21, \sqrt{0.64} = 0.8$.

Worthless (0)

W1 Incorrect answer without work. (Note 1st *).

QUESTION 3

Part (a)	10 marks	Att 3
Part (b)	20 (10, 10) marks	Att 6(3, 3)
Part (c)	20 (5, 5, 5, 5,) marks	Att 8(2, 2, 2, 2)

Part (a) **10 marks** **Att 3**

3(a) Kate went to the cinema. She bought a ticket at €8.50 and then bought popcorn costing €4.40. How much change did Kate get from a €20 note?

Part (a) **10 marks** **Att 3**

*	**	***
$€8.50 + €4.40 = €12.90$	$€20.00 - €8.50 = €11.50$	$€20.00 - €4.40 = €15.60$
$€20.00 - €12.90 = €7.10$	$€11.50 - €4.40 = €7.10$	$€15.60 - €8.50 = €7.10$

- * Accept 710c, (7.10)
- * Final subtraction step subject to maximum deduction of 3 marks.
- * No penalty for the omission of € symbol.

Blunders (-3)

- B1 Correct answer without work.
- B2 Calculates the cost of the ticket and the popcorn but fails to find the change.
- B3 Fails to find total cost i.e. no addition.
- B4 Operation other than subtraction when finding the change.
- B5 Operation other than addition when finding total cost.
- B6 Decimal error e.g. €1.29 (Note: 1st* above).

Slips (-1)

- S1 Numerical errors to a max of 3.

Attempts (3 marks)

- A1 Any attempt at addition /subtracation.

Worthless (0)

- W1 Incorrect answer without work.
- W2 Multiplication or division of the given numbers.

Part (b) (i)**10 marks****Att3**

3(b) (i) VAT at 13.5% is added to a bill of €860 Calculate the total bill.
--

Part (b) (i)**10 marks****Att3**

$100\% = 860$	$13.5\% = \frac{13.5}{100}$	860×1.135
$1\% = \frac{860}{100}$	$VAT = \frac{13.5}{100} \times 860$	$Total\ Bill = €976.10$
$113.5\% = \frac{860}{100} \times 113.5$	$= 116.10 \left(\frac{1161}{10} \right)$	
$= 8.60 \times 113.5$	$Total\ Bill = 860 + 116.10$	
$Total\ Bill = €976.10$	$Total\ Bill = €976.10$	

* €116.10 without work and stops merits **4** marks.

Blunders (-3)

B1 Correct answer without work.

B2 Decimal error.

B3 Inverts as $\frac{100}{113.5}$ or $\frac{100}{13.5}$ and continues (giving answers 757.71 or 6370.37).B4 Mishandles 13.5% e.g. 860×13.5 or $860 \div 13.5$. Note: {860 must be used}.

B5 860 taken as 113.5%.

B6 No addition of VAT (as per candidates work) to the bill.

B7 Subtraction of VAT (as per candidates work) from the bill.

Slips (-1)

S1 Numerical errors to a max of 3.

Misreadings (-1)

M1 Reads as 15.3% or €680.

*Attempts (3 marks)*A1 $\frac{13.5}{100}$ and stops. or $\frac{860}{100}$ and stops.A2 $100\% = 860$ and stops.A3 $100 \times \frac{13.5}{860}$ and stops. or $\frac{860}{13.5}$ and stops.A4 $860 + 13.5\%$ and stops.*Worthless (0)*

W1 Incorrect answer without work.

W2 $860 + 13.5 = 873.5$ and stops or continues.

Part (b) (ii)

10 marks

Att 3

3(b) (ii)

€4750 is invested at 3.7% per annum

What is the amount of the investment at the end of one year?

Part (b) (ii)

10 marks

Att 3

		
$1\% = \frac{4750}{100}$	$I = \frac{P \times R}{100}$	Amount = 4750×1.037
$3.7\% = \frac{4750}{100} \times 3.7$	$I = \frac{4750 \times 3.7}{100}$	Amount = $\text{€}4925.75 \left(\frac{19703}{4} \right)$
Interest = $175.75 \cdot \left(\frac{703}{4} \right)$	Interest = 175.75	
Amount = $4750 + 175.75$	Amount = $\text{€}4925.75$	
Amount = $\text{€}4925.75$		

* €175.75 (without work) and stops \Rightarrow 4 marks.

Blunders (-3)

B1 Correct answer without work. 

B2 Mishandles 3.7%. e.g. $\frac{4750 \times 100}{3.7}$ {No penalty if already penalised in b (i)}

B3 Decimal error (once only).

B4 Stops at interest i.e. fails to calculate amount.

B5 Subtracts to calculate amount.

B6 Mathematical error(s) working with $\frac{4750}{100} \times 3.7$.

B7 1.037 treated as 1.37 .

Slips (-1)

S1 Numerical errors to a max of 3.

Misreadings (-1)

M1 Reads as €4570.

M2 3.7% written as 7.3%.

Attempts (3 marks)

A1 Correct formula with or without substitution and stops.

A2 Some use of 100 in attempt to find percentage e.g. $3.7\% = \frac{3.7}{100}$ or 1.037 and stops.

A3 $4750 + 3.7\%$ and stops.

Worthless (0)

W1 Incorrect answer without work.

W2 $4750 + 3.7 = 4753.7$ and stops or continues.

Part (c)

20 (5, 5, 5, 5) marks

Att 8 (2, 2, 2, 2)

3(c) Darragh's annual wage is €48 000.
He pays income tax at the rate of 20% on the first €34000 of his wage and income tax at the rate of 41% on the remainder of his wage.
Darragh has an annual tax credit of €3600.

Part (c) (i)

5 marks

Att 2

3(c) (i) Find the tax on the first €34000 of his wage, calculated at the rate of 20%.

Part (c) (i)

5 marks

Att 2



100% = 34000	$\text{Tax} = \frac{34000}{100} \times 20$	$\text{Tax} = 34000 \times 0.2$	$20\% = \frac{1}{5}$
1% = 340	$\text{Tax} = \text{€}6800$	$\text{Tax} = \text{€}6800$	$34000 \div 5$
20% = 6800			$\text{Tax} = \text{€}6800$
$\text{Tax} = \text{€}6800$			

* No penalty for missing € symbol.

Blunders (-3)

- B1 Correct answer without work. 
B2 Mishandles 20%, e.g. $34000 \times 20 = 680000$ or $34000 \div 20 = 1700$
B3 Uses €48000 instead of €34000.
B4 Decimal error.

Slips (-1)

- S1 Numerical errors to a max of 3

Attempts (2 marks)

- A1 Some use of 100 in attempt to find percentage e.g. $20\% = \frac{20}{100}$ or 0.2 and stops.
A2 $20\% = \frac{1}{5}$
A3 Writes $34000 + 20\%$ and stops.

Worthless (0)

- W1 Incorrect answer without work

Part (c) (ii)

5 marks

Att 2

3(c) (ii) Find the tax on the remainder of his wage, calculated at the rate of 41%.

Part (c) (ii)

5 marks

Att 2

✍ (ii) Remainder of wage = €48 000 – €34 000 = €14,000		
100% = 14 000	Tax = $\frac{14000}{100} \times 41 = 5740$	Tax = 14 000 × 0.41
1% = 140		Tax = 5 740
41% = 5740		
Tax = 5740		

* No penalty for missing € symbol.

Blunders (-3)

- B1 Correct answer without work. ✍
- B2 Mishandles 41%, e.g. $14000 \div 41$ [No penalty if already penalised in (c) (i)].
- B3 Does not use €14 000.
- B4 Decimal error.

Slips (-1)

- S1 Numerical errors to a max of 3.

Attempts (2 marks)

- A1 Some use of 100 in attempt to find percentage e.g. $41\% = \frac{41}{100} = 0.41$ and stops.
- A2 48 000 - 34 000 or 14 000 and stops.

Worthless (0)

- W1 Incorrect answer without work.

Part (c) (iii)

5 marks

Att 2

3(c) (iii) Hence calculate Darragh's gross tax.

Part (c) (iii)

5 marks

Att 2

 **(iii)** Darragh's gross tax = €6800 + €5740 = €12 540

- * Allow candidates incorrect answers from parts (i) and (ii).
- * No penalty for missing € symbol.

Blunders (-3)

- B1 Correct answer without work. 
- B2 Subtracts to find gross tax e.g. €6800 – €5740 = €1060
- B3 Misuse of tax credit.

Slips (-1)

- S1 Numerical errors to a max of 3.

Attempts (2)

- A1 Answer from c (i) and /or c (ii) written in this part.

Worthless (0)

- W1 Incorrect answer without work

Part (c) (iv)

5 marks

Att 2

3(c) (iv) Calculate Darragh's take home pay.

Part (c) (iv)

5 marks

Att 2

 Tax due = €12 540 - €3600
= €8940
Take home pay = €48 000 - €8940
Take home pay = €39 060

- * Allow candidate's incorrect gross tax figure from (c) (iii).
- * No penalty for missing € symbol.

Blunders (-3)

- B1 Correct answer without work. 
- B2 Misuse or no use of tax credit e.g. €12 540 + €3600
- B3 Decimal error.

Slips (-1)

- S1 Numerical errors to a max of 3.

Attempts (2)

- A1 Answer from c (iii) written in this part.

Worthless (0)

- W1 Incorrect answer without work.

QUESTION 4

Part (a)	10 (5, 5) marks	Att 4(2, 2)
Part (b)	20 (10, 10) marks	Att 6(3, 3)
Part (c)	20 (5, 5, 5, 5) marks	Att 8(2, 2, 2, 2)

Part (a) **10(5, 5) marks** **Att 4(2,2)**

4(a) If $a = 5$ and $b = 7$, find the value of:



(i) $9a + b$



(ii) $ab + 13$

Part (a) (i) **5 marks** **Att 2**

4(a) (i) If $a = 5$ and $b = 7$, find the value of:

(i) $9a + b$

Part (a) (i) **5 marks** **Att 2**



(i) $9a + b = 9(5) + 7 = 45 + 7 = 52$

* $45 + 7 \Rightarrow$ **4** marks.

Blunders (-3)

- B1 Correct answer without work.
- B2 Leaves $9(5)$ in the answer.
- B3 Incorrect substitution and continues
- B4 Breaks order i.e. $[9(5+7)=9(12)=108]$.
- B5 Treats $9(5)$ as 14 or 95.
- B6 Combines $9a + b$ to give $9ab$ and continues.

Slips (-1)

- S1 Numerical errors to a max of 3.
- S2 Treats as $9a - b$.
- S3 Treats as $9b + a$.

Attempts (2 marks)

- A1 Substitutes for either a or b and stops e.g. $9(5)$.
- A2 Writes 7 or 5 in this part.
- A3 Any correct step.

Worthless (0)

- W1 Incorrect answer with no work.
- W2 Writes as $9ab$ and stops.

Part (a) (ii)

5 marks

Att 2

4(a) (ii)

If $a = 5$ and $b = 7$, find the value of:

(ii) $ab + 13$

Part (a) (ii)

5 marks

Att 2



$$ab + 13 = 5(7) + 13 = 35 + 13 = 48$$

* $35 + 13 \Rightarrow$ **4** marks.

Blunders (-3)

- B1 Correct answer without work.
- B2 Leaves $5(7)$ in the answer.
- B3 Incorrect substitution and continues
- B4 Breaks order i.e. $[5(7+13)=5(20)=100]$.
- B5 Treats $5(7)$ as 12 or 57.
- B6 Combines $ab+13$ to give $13ab$ and continues.

Slips (-1)

- S1 Numerical errors to a max of 3.
- S2 Treats as $ab-13$.

Attempts (2 marks)

- A1 Substitutes for either a or b and stops e.g. $a(7)$.
- A2 Writes 7 or 5 in this part.
- A3 Any correct step.

Worthless (0)

- W1 Incorrect answer with no work.
- W2 Writes as $13ab$ and stops.

Part (b) (i)

10 marks

Att 3

4(b) (i)

Solve the equation $3(2x - 1) = 4x + 9$

Part (b) (i)

10 marks

Att 3

~~✗~~

$$3(2x - 1) = 4x + 9$$

$$6x - 3 = 4x + 9$$

$$6x - 4x = 3 + 9$$

$$2x = 12$$

$$x = \frac{12}{2}$$

$$x = 6$$

Blunders (-3)

- B1 Correct answer without work. ~~✗~~ ($x=6$ stated or substituted)
B2 Error in distributive law and continues. e.g. $6x - 1 = 4x + 9$
B3 Error in transposition. (each time).
B4 Combines “x’s” to “numbers” and continues. e.g. $6x - 3 = 3x$ or $4x + 9 = 13$ or $2x - 1 = x$
B5 Stops at $2x = 12$ or similar.

Slips (-1)

- S1 Numerical errors to a max of 3.
S2 Leaves as $x = \frac{12}{2}$ or similar.

Attempts (3 marks)

- A1 Any substitution for values of x other than $x=6$.
A2 Any correct step. e.g. $(2x-1) = \frac{4x+9}{3}$

Worthless (0)

- W1 Combines “x’s” to “numbers” and stops
W2 Incorrect answer with no work.

Part (b) (ii)

10 marks

Att 3

4(b) (ii)

Multiply $(5x - 2)$ by $(3x + 4)$.

Write your answer in its simplest form.

Part (b) (ii)

10 marks

Att 3



$(5x - 2)(3x + 4)$	$(3x + 4)(5x - 2)$	$(5x - 2)(3x + 4)$
$15x^2 + 20x - 6x - 8$	$15x^2 - 6x + 20x - 8$	$5x(3x + 4) - 2(3x + 4)$
$15x^2 + 14x - 8$	$15x^2 + 14x - 8$	$15x^2 + 20x - 6x - 8$
		$15x^2 + 14x - 8$

* $15x^2 + 20x - 6x - 8$ merits 7 marks.

Blunders (-3)

B1 Correct answer without work.

B2 Error in distribution.

B3 Combines “x’s” to “numbers” and continues. e.g. $5x - 2 = 3$ or $3x + 4 = 7x$.

B4 Fails to group or groups incorrectly.

Slips (-1)

S1 Numerical errors to a max of 3.

Attempts (3 marks)

A1 Any correct multiplication. e.g. $15x$.

A2 Any correct grouping of terms.

A3 A correct step.

A4 Substitutes a value of “x” and continues correctly.

A5 Treats as $(5x - 2) \pm (3x + 4)$ to give $8x + 2$ or $2x - 6$.

Worthless (0)

W1 Combining unlike terms and stops.

W2 No distribution but A2 or A5 may apply to subsequent work e.g. gathering of terms.

Part (c)

20 (5, 5, 5, 5) marks

Att 8 (2, 2, 2, 2)

4(c) Shane is x years old. Eileen is three years younger than Shane.

Part (c) (i)

5 marks

Att 2

4(c) (i) Find Eileen's age in terms of x .

Part (c) (i)

5 marks

Att 2

$$x - 3$$

* Algebraic work required to earn marks.

Blunders (-3)

B1 Incorrect expression of Eileen's age other than misreadings below.

Misreadings (-1)

M1 Answer given as $x + 3$.

M2 Answer given as $3x$.

Attempts (2 marks)

A1 Any effort at forming an expression. e.g. Eileen's age = y .

Worthless (0 marks)

W1 Eileen's age given as a constant or x .

W2 Inequality appears.

Part (c) (ii)

5 marks

Att 2

4(c) (ii) If the sum of Shane's age and Eileen's age is 47, write down an equation in x to represent this information.

Part (c) (ii)

5 marks

Att 2

$$x + x - 3 = 47$$

* Accept candidates answer from previous work.

Blunders (-3)

B1 Error in forming equation.

Attempts (2 marks)

A1 Answer from part c (i) written down and stops.

A2 Any effort at forming an expression.

A3 Writes Shane's age and stops. i.e. x

Part (c) (iii)

5 marks

Att 2

4(c) (iii)

Solve the equation that you formed in part (ii) above, for x .

Part (c) (iii)

5 marks

Att 2



$$x + x - 3 = 47$$

$$2x = 47 + 3$$

$$2x = 50$$

$$x = \frac{50}{2}$$

$$x = 25$$

* Accept candidates answer from previous work.

Blunders (-3)

- B1 Correct answer without work. ($x=25$ stated or substituted)
- B2 Error in transposition.
- B3 Error in grouping terms or fails to group.
- B4 Combines “x's” to “numbers” and continues. e.g. $x + x - 3 = -x$
- B5 Stops at $2x = 50$ or similar.

Slips (-1)

- S1 Numerical errors to a max of 3.
- S2 Leaves as $x = \frac{50}{2}$ or similar.

Attempts (2 marks)

- A1 Any substitution for values of x other than $x=25$.
- A2 Answer from part c(ii) written down and stops.
- A3 Any effort at solving equation.
- A4 Any correct step.

Worthless (0)

- W1 Combines “x's” to “numbers” and stops. (Note A3 above)
- W2 Incorrect answer with no work.

Part (c) (iv)

5 marks

Att 2

4(c) (iv) When Eileen is $2x + 5$ years old, find the sum of Shane's age and Eileen's age

Part (c) (iv)

5 marks

Att 2

	Allow
	
Eileen's age $\rightarrow 2x + 5 = 2(25) + 5 = 50 + 5 = 55$	Eileen's age = $2x + 5$
Shane's age $\rightarrow 55 + 3 = 58$	Shane's age = $2x + 8$
Sum of Shane's age and Eileen's age $= 55 + 58 = 113$	Sum of Shane's age and Eileen's age $= 2x + 5 + 2x + 8 = 4x + 13$

* Accept candidates answer from previous work.

Blunders (-3)

- B1 Correct answer without work. 
- B2 Error in grouping terms or fails to group.
- B3 Combines "x's" to "numbers" and continues. e.g. $2x + 5 + 2x + 8 = 7x + 10$.
- B4 Only one age calculated.

Misreadings (-1)

- M1 Takes Shane's age as x and continues $2x + 5 + x = 3x + 5$.

Slips (-1)

- S1 Numerical errors to a max of 3.
- S2 Leaves as $55 + 58$ or similar.

Attempts (2 marks)

- A1 Any correct step.
- A2 Writes answer from c (iii) and stops.

Worthless (0)

- W1 Incorrect answer with no work.
- W2 Works with $2x + 5 = 47$

QUESTION 5

Part (a)	5 marks	Att 2
Part (b)	20(5, 5, 5, 5) marks	Att 8(2, 2, 2, 2)
Part (c)	25(5, 5, 15) marks	Att 9(2, 2, 5)

Part (a) **5 marks** **Att 2**

5 (a) Find the values of x for which $3x + 2 \leq 8, x \in \mathbf{N}$

Part (a) **5 marks** **Att 2**

$3x + 2 \leq 8$
 $3x \leq 8 - 2$
 $3x \leq 6$ or
 $x \leq 2$
 $\{0, 1, 2\}$

A horizontal number line with three solid black dots at positions 0, 1, and 2. The positions are labeled with the numbers 0, 1, and 2 below the line.

Blunders (-3)

- B1 Correct answer without work.
- B2 Error in transposition.
- B3 Combines “x’s” to “numbers”. e.g.. $5x \leq 8$ and continues.
- B4 Mishandles the direction of inequality e.g. $3x \geq 6$
- B5 Treats inequality as equality and continues.

Slips (-1)

- S1 Numerical errors to a max of 3.
- S2 \leq taken as $<$
- S3 Each missing or incorrect value of x subject to a max of 3.

Misreadings (-1)

- M1 $2x + 3 \leq 8$, and continues.

Attempts (2 marks)

- A1 Attempt at transposition and stops.
- A2 0, 1 or 2 substituted for x .
- A3 Number line with one or more of the correct elements clearly indicated. (Ignore arrows)

Worthless (0)

- W1 Incorrect answer with no work.e.g. $\{1, 2, 3, 4, 5, 6, 7, 8, \dots\}$.

Part (b) (i)

5 marks

Att 2

5(b) (i)

Factorise:

$$4a + ab$$

Part (b) (i)

5 marks

Att 2

$$a(4 + b)$$

Blunders (-3)

B1 Removes factor incorrectly.

Attempts (2 marks)

A1 Indication of common factor. e.g. underline a 's and stops.

Part (b) (ii)

5 marks

Att 2

5(b) (ii)

Factorise:

$$2x - 2y + cx - cy$$

Part (b) (ii)

5 marks

Att 2

	$2x - 2y + cx - cy$		$2x - 2y + cx - cy$
	$2(x - y) + c(x - y)$	or	$x(2 + c) - y(2 + c)$
	$(2 + c)(x - y)$		$(x - y)(2 + c)$

- * Accept also (with or without brackets) for 5 marks any of the following
($2 + c$) and ($x - y$) [The word **and** is written down.]
($2 + c$) or ($x - y$) [The word **or** is written down.]
($2 + c$), ($x - y$) [A comma is used]

Blunders (-3)

B1 Correct answer without work. 

B2 Stops after first line of correct factorisation. e.g. $2(x - y) + c(x - y)$ or equivalent.

B3 Error(s) in factorising any pair of terms.

B4 Incorrect common factor and continues. e.g. $y(-2 - c) + x(2 + c)$

Slips (-1)

S1 ($2 + c$) \pm ($x - y$)

S2 Correct first line of factorisation but ends as $2c(x - y)$ or $xy(2 + c)$.

Attempts (2 marks)

A1 Pairing off, or indication of common factors and stops.

A2 Correctly factorises any pair and stops.

Part (b) (iii)

5 marks

Att 2

5(b) (iii)

Factorise:

$$x^2 - 2x - 24$$

Part (b) (iii)

5 marks

Att 2

$x^2 - 2x - 24$ $x^2 - 6x + 4x - 24$ $x(x - 6) + 4(x - 6)$ $(x + 4)(x - 6)$		$\frac{-(-2) \pm \sqrt{(-2)^2 - 4(1)(-24)}}{2(1)}$ $\frac{2 \pm \sqrt{4 + 96}}{2} = \frac{2 \pm 10}{2}$ $\frac{12}{2} = 6 \quad \text{and} \quad \frac{-8}{2} = -4$ $\Rightarrow (x - 6)(x + 4)$
$\Rightarrow (x + 4)(x - 6)$		

- * Accept also (with or without brackets) for 5 marks any of the following
 $(x - 6)$ and $(x + 4)$ [The word **and** is written down.]
 $(x - 6)$ or $(x + 4)$ [The word **or** is written down.]
 $(x - 6)$, $(x + 4)$ [A comma is used]

Blunders (-3)

- B1 Incorrect two term linear factors of $x^2 - 2x - 24$ formed from correct (but inapplicable) factors of x^2 and -24 . e.g $(x - 12)(x + 2)$.
- B2 Incorrect factors of x^2 .
- B3 Incorrect factors of -24 .
- B4 Correct cross method but factors not shown and stops.
- B5 $x(x - 6) + 4(x - 6)$ or similar and stops.
- B6 Incorrect common factor and continues.
- B7 Incorrect quadratic formula and continues.
- B8 Error in quadratic formula.
- B9 Answer left as roots.
- B10 Sign error in substituted formula.
- B11 Error in square root or square root ignored.

Slips (-1)

- S1 Numerical errors to a max of 3.
- S2 $(x + 4) \pm (x - 6)$.

Attempts (2 marks)

- A1 Correct quadratic equation formula quoted and stops
- A2 Correct factors of either x^2 or ± 24 .
- A3 Any correct step.

Worthless (0 marks)

- W1 $x^2 - 2x = 24$ or similar and stops.
- W2 Combines "x's" to "numbers" and continues or stops.

Part (b) (iv)

5 marks

Att 2

5(b) (iv)

Factorise:

$$144 - y^2$$

Part (b) (iv)

5 marks

Att 2

$$(12 - y)(12 + y)$$

- * Accept also (with or without brackets) for 5 marks any of the following
(12 - y) and (12 + y) [The word **and** is written down.]
(12 - y) or (12 + y) [The word **or** is written down.]
(12 - y) ,(12 + y) [A comma is used]
- * Quadratic equation formula method is subject to slips and blunders.
- * $(\sqrt{144} - y)(\sqrt{144} + y)$ merits 5 marks.

Blunders (-3)

- B1 Incorrect two term linear factors of $144 - y^2$ formed from correct (but inapplicable) factors of 144 and $-y^2$. e.g $(144 - y)(1 + y)$.
- B2 Incorrect factors of 144.
- B3 Incorrect factors of $-y^2$.
- B4 $(y - 12)(y + 12)$.
- B5 $(144 + y)(144 - y)$.
- B6 Answer left as roots. ($y = \pm 12$)

Slips (-1)

S1 $(12 - y) \pm (12 + y)$

Attempts (2 marks)

- A1 Correct factors of 144 only.
- A2 Correct factors of $\pm y^2$ only.
- A3 ± 12 or $\pm y$ appears.
- A4 $144 - y^2 = (12)(12) - (y)y$ and stops.
- A5 Mention of the difference of two squares .e.g. $\{(144)^2 - y^2\}$
- A6 Correct quadratic equation formula quoted and stops.
- A7 $\sqrt{144}$

Worthless (0 marks)

- W1 Combines “y’s” to “numbers” and continues or stops.

Part(c) (i)

5 marks

Att 2

5(c)(i) Express $\frac{x-1}{5} - \frac{x-2}{7}$ as a single fraction and give your answer in its simplest form.

Part(c) (i)

5 marks

Att2



$$\begin{aligned} & \frac{x-1}{5} - \frac{x-2}{7} \\ & \frac{7(x-1) - 5(x-2)}{35} \\ & \frac{7x-7-5x+10}{35} \\ & \frac{2x+3}{35} \end{aligned}$$

Blunders (-3)

B1 Correct answer without work. ✗

B2 Error(s) in distribution. e.g. $7(x-1) = 7x-1$

B3 Mathematical error e.g. $-7+10 = -3$. $2(-1) = 2$.

B4 Incorrect common denominator and continues.

B5 Incorrect numerator from candidate's denominator e.g. $\frac{5(x-1)-7(x-2)}{35}$.

B6 No simplification of numerator.

B7 Omitting denominator.

Slips (-1)

S1 Drops denominator.

S2 Numerical error to a max of 3.

S3 Answer not in simplest form. e.g. $\frac{4x+6}{70}$.

Attempts (2 marks)

A1 35 only or a multiple of 35 only appears.

A2 Any correct step.

Worthless (0)

W1 $\left(\frac{x-1}{5}\right)\left(\frac{x-2}{7}\right)$ and stops.

W2 $\frac{x-1}{5} - \frac{x-2}{7} = \frac{2x-3}{-2}$

Part(c) (ii)

5 marks

Att2

5(c) (ii)

Hence, or otherwise, solve the equation

$$\frac{x-1}{5} - \frac{x-2}{7} = 1$$

Part(c) (ii)

5 marks

Att2



$$\frac{2x + 3}{35} = 1$$

$$2x + 3 = 35$$

$$2x = 35 - 3$$

$$2x = 32$$

$$x = \frac{32}{2}$$

$$x = 16$$

* Accept candidates answer from previous work.

Blunders (-3)

B1 Correct answer without work.

B2 Error in transposition. (each time)

Slips (-1)

S1 Numerical error to a max of 3.

S2 Leaves as $\frac{32}{2}$.

Attempts (2 marks)

A1 Answer from (c) (i) written in this part or worked again in this part.

A2 Any correct step and stops.

Part(c) (iii)

15 marks

Att 5

5(c) (iii) Solve for x and for y :

$$3x + 2y = 73$$

$$4x + y = 59$$

Part(c) (ii)

15 marks

Att 5



	I	II
$3x + 2y = 73$	$3x + 2y = 73$	$2y = 73 - 3x$
$4x + y = 59$	$4x + y = 59$	$y = \frac{73 - 3x}{2}$
$3x + 2y = 73$	$12x + 8y = 292$	$4x + \left(\frac{73 - 3x}{2}\right) = 59$
$-8x - 2y = -118$	$-12x - 3y = -177$	$8x + 73 - 3x = 118$
$-5x = -45$	$5y = 115$	$5x = 118 - 73$
$5x = 45$	$y = \frac{115}{5} = 23$	$5x = 45$
$x = \frac{45}{5} = 9$	$\Rightarrow x = 9$	$x = \frac{45}{5} = 9$
$\Rightarrow y = 23$		$\Rightarrow y = 23$

* Apply only **one** blunder deduction (B2 or B3) to any error(s) in establishing the first equation in terms of x only or the first equation in terms of y only.

* Finding the second variable is subject to a maximum deduction of (3).

Blunders (-3)

B1 Correct answers without work.

B2 Error(s) in establishing the first equation in terms of x only [$5x = 45$] or the first equation in terms of y only [$5y = 115$] through elimination by cancellation.

B3 Error(s) in establishing the first equation in terms of x only [$5x = 45$] or the first equation in terms of y only [$5y = 115$] through elimination by substitution.

B4 Errors in transposition in solving the first one variable equation.

B5 Errors in transposition when finding the second variable.

B6 Incorrect substitution when finding second variable.

B7 Finds one variable only.

Slips (-1)

S1 Numerical errors to a max of 3

Attempts (5 marks)

A1 Attempt at transposition and stops.

A2 Multiplies either equation by some number and stops .

Worthless (0 marks)

W1 Incorrect values for x or y substituted into the equations.

QUESTION 6

Part (a)	10 (5, 5) marks	Att 4(2, 2,)
Part (b)	25 (15, 10) marks	Att 8(5, 3)
Part (c)	15 (5, 5, 5) marks	Att 6(2, 2, 2)

Part (a) **10(5, 5) marks** **Att 4(2, 2)**

6 (a)

$f(x) = 3x - 1.$ Find:

- (i) $f(5)$
- (ii) $f(-4)$

Part (a) (i) **5 marks** **Att 2**

6(a) (i) $f(x) = 3x - 1.$ Find: $f(5)$

Part (a) (i) **5 marks** **Att2**

(i) $f(5) = 3(5) - 1 = 15 - 1 = 14$

Blunders (-3)

- B1 Leaves $3(5)$ in the answer
- B2 Combines “x’s” to “numbers” and continues e.g. $3x - 1 = 2x = 2(5) = 10$
- B3 Mathematical error. e.g. $15 - 1 = -14$
- B4 Breaks order i.e. $3(5 - 1) = 3(4) = 12$

Slips (-1)

- S1 Numerical errors to a max of 3.
- S2 Leaves x in the answer e.g. $14x$

Misreadings (-1)

- M1 Correct substitution of any number other than 5 and continues.

Attempts (2marks)

- A1 Substitutes for x and stops. i.e. $3(5)$
- A2 Treats as equation and continues or stops. i.e. $3x - 1 = 5$

Worthless (0)

- W1 Combines “x’s” to “numbers” and stops.
- W2 Ignores x giving $3 - 1 = 2$.
- W3 $5[f(x)] = 15x - 5$
- W4 Replaces coefficient i.e. $3x \rightarrow 5x$.
- W5 Incorrect answer without work.

Part (a) (ii)

5 marks

Att 2

6(a) (ii) $f(x) = 3x - 1$. Find: $f(-4)$

Part (a) (ii)

5 marks

Att2

(ii) $f(-4) = 3(-4) - 1 = -12 - 1 = -13$

Blunders (-3)

B1 Leaves $3(-4)$ in the answer

B2 Combines "x's" to "numbers" and continues e.g. $3x - 1 = 2x = 2(-4) = -8$

B3 Mathematical error. e.g. $-12 - 1 = 13$

B4 Breaks order i.e. $3(-4 - 1) = 3(-5) = -15$

Slips (-1)

S1 Numerical errors to a max of 3.

S2 Leaves x in the answer e.g. $-13x$.

Misreadings (-1)

M1 Correct substitution of any negative number other than -4 and continues.

Attempts (2marks)

A1 Substitutes for x and stops. i.e. $3(-4)$

A2 Treats as equation and continues or stops i.e. $3x - 1 = -4$

Worthless (0)

W1 Combines "x's" to "numbers" and stops.

W2 Ignores x giving $3 - 1 = 2$.

W3 $-4[f(x)] = -12x - 4$.

W4 Replaces coefficient i.e. $3x \rightarrow -4x$.

W5 Incorrect answer without work.

Part (b)

25 (15, 10) marks

Att 8 (5, 3)

6(b)

Draw the graph of the function

$$f: x \rightarrow x^2 - 3x - 1$$

in the domain $-1 \leq x \leq 4$, where $x \in \mathbf{R}$

Part (b) Table

15 marks

Att 5

$f(x)$	=	x^2	$-3x$	-1			x	-1	0	1	2	3	4
$f(-1)$	=	$(-1)^2$	$-3(-1)$	-1	=	3	x^2	1	0	1	4	9	16
$f(0)$	=	$(0)^2$	$-3(0)$	-1	=	-1	$-3x$	3	0	-3	-6	-9	-12
$f(1)$	=	$(1)^2$	$-3(1)$	-1	=	-3	-1	-1	-1	-1	-1	-1	-1
$f(2)$	=	$(2)^2$	$-3(2)$	-1	=	-3	$f(x)$	3	-1	-3	-3	-1	3
$f(3)$	=	$(3)^2$	$-3(3)$	-1	=	-1							
$f(4)$	=	$(4)^2$	$-3(4)$	-1	=	3							

* Error(s) in each row /column attract a maximum deduction of 3.

Blunders (-3)

- B1 “ $-3x$ ” taken as “ -3 ” all the way. [In row headed $-3x$ by candidate]
- B2 “ -1 ” calculated as “ $-x$ ” all the way. [In row headed “ -1 ” by candidate]
- B3 Adds in top row when evaluating $f(x)$.
- B4 Omits “ -1 ” row.
- B5 Omits “ $-3x$ ” row.
- B6 Omits a value in the domain (each time).
- B7 Each incorrect image without work.

Slips (-1)

- S1 Numerical errors to a max of 3 in any row / column.

Misreadings (-1)

- M1 Misreads “ x^2 ” as “ $-x^2$ ” and places “ $-x^2$ ” in the table or function
- M2 Misreads “ $-3x$ ” as “ $3x$ ” and places “ $3x$ ” in the table or function.
- M3 Misreads “ -1 ” as “ 1 ” and places “ 1 ” in the table or function

Attempts (5 marks)

- A1 Omits “ x^2 ” row from table or treats “ x^2 ” as $\pm 2x$.
- A2 Any effort at calculating point(s).
- A3 Only one point calculated and stops.

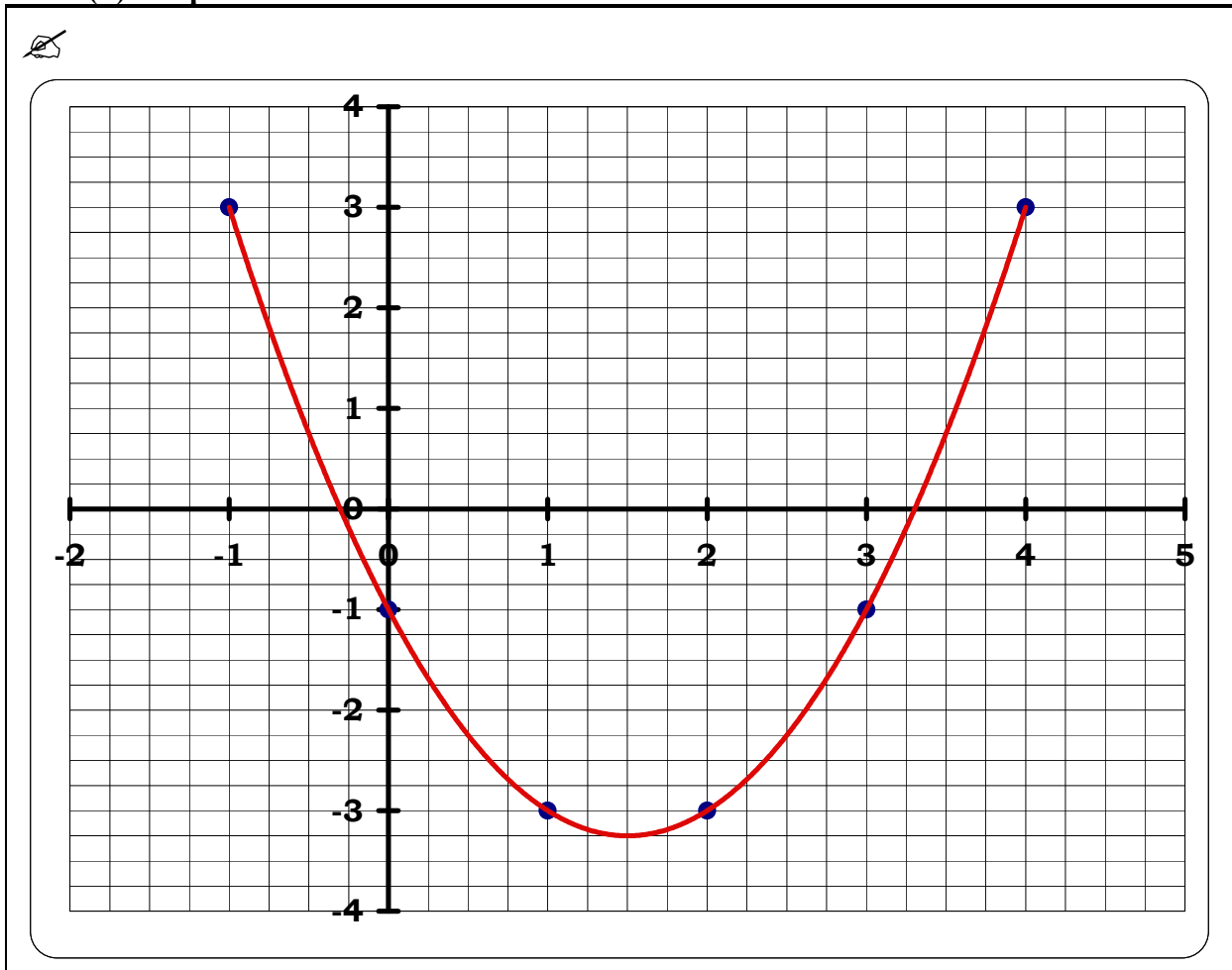

- * Accept candidate's values from previous work.
- * Only **one** correct point **graphed correctly** \Rightarrow Att 5 + Att 3
- * **Correct graph but no table** \Rightarrow full marks i.e. **(15+10)** marks.
- * Accept reversed co-ordinates if
 - (i) if axes not labelled or (ii) if axes are reversed to compensate (see B1 below)

Blunders (-3)

- B1 Reversed co-ordinates plotted against non-reversed axes (once only) {See 4th * above}.
- B2 Scale error (once only).
- B3 Points not joined or joined in incorrect order (once only).

Slips (-1)

- S1 Each point of candidate graphed incorrectly. {Tolerance ± 0.25 }
- S2 Each point from table not graphed [See 2nd * above].

Attempts (3 marks)

- A1 Axes drawn (need not be labelled).
- A2 Some effort to plot a point {See 2nd * above}.

Part(c) (i)

5 marks

Att 2

6(c) (i) Given that $y = x + 2$, complete the table below

Part(c) (i)

5 marks

Att 2

x	-1	0	1	2
y	1	2	3	4

* Accept candidate's values without work.

Slips(-1)

S1 Each “ y ” value omitted or incorrect.

Misreadings (-1)

M1 Misreads $y = x + 2$ as $y = x - 2$.

Attempts(2marks)

A1 Any one correct “ y ” value.

A2 Any effort at calculating points.

Worthless (0)

W1 Copies x values into y row.

W2 All y values incorrect with no work shown. (See M1 above).

Part(c) (ii)

5 marks

Att 2

6(c) (ii)

On the grid below, the graph of the line $y = 4 - x$ is drawn.

Using your answers from (i), draw the graph of $y = x + 2$ on the same grid.

Part(c) (ii) Graph

5 marks

Att 2

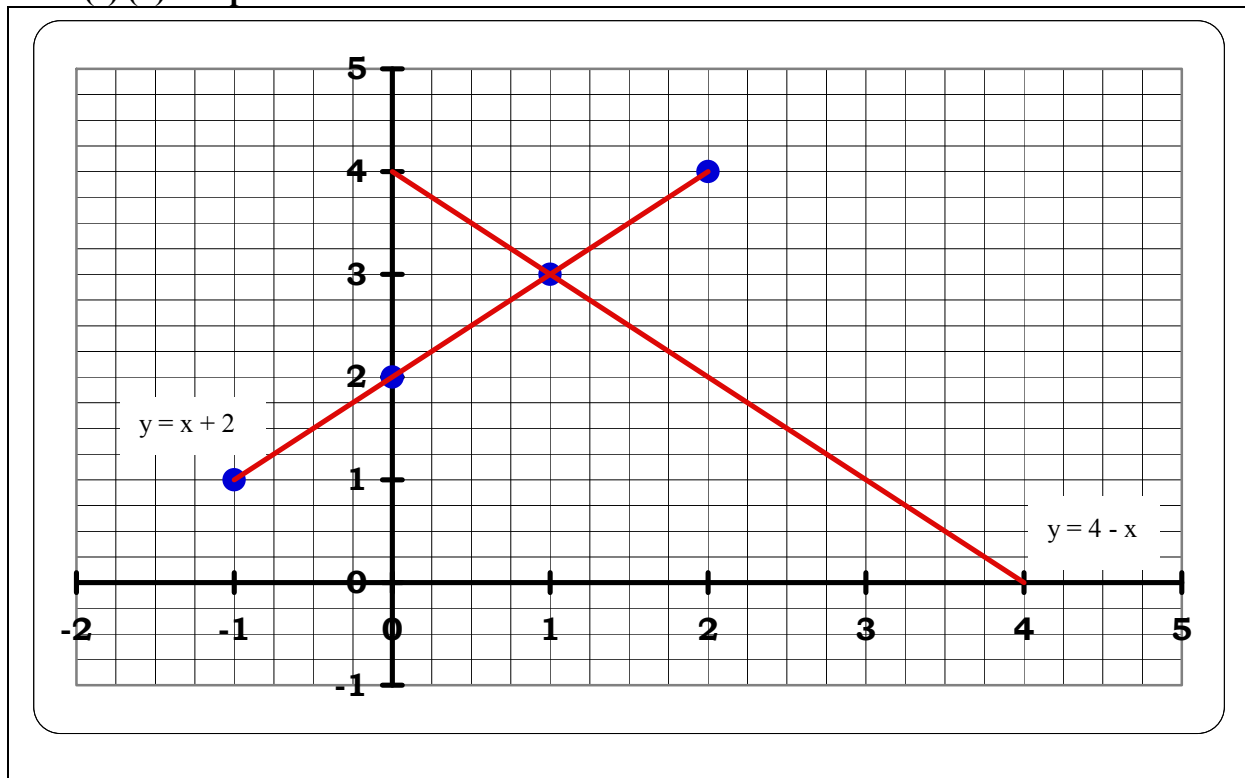

* Accept candidate's values from previous work.

Blunders (-3)

B1 Reversed co-ordinates (y, x) plotted.

B2 Points not joined or joined in incorrect order.

Slips (-1)

S1 Each point of candidate graphed incorrectly. {See B1}

S2 Each point from table not graphed or not contained on the candidate's graph.

Attempts (2 marks)

A1 Any one correct point plotted.

Worthless (0)

W1 No correct point plotted. (See B1 above).

Part(c) (iii) Intersection**5 marks****Att2****6(c) (iii)**

Use the graphs drawn in **6 (c) (ii)** to write down the coordinates of the point of intersection of the two lines $y = 4 - x$ and $y = x + 2$.

Part(c) (iii) Intersection**5 marks****Att2**

Point of intersection = (1, 3)

- * Accept correct answer based on candidate's graph fully plotted.
i.e. 4 points correctly plotted from c(i) otherwise attempt marks at most.

Blunders(-3)

- B1 Answer not presented in designated box.
B2 Answer beyond tolerance. {Tolerance ± 0.25 }.
B3 Reversed co-ordinates (y, x) plotted.

Attempts(2marks)

- A1 Point of intersection highlighted on graph.

Worthless(0)

- W1 Answers outside of tolerance without graphical indication.
W2 Incorrect answer from candidate's graph.



Coimisiún na Scrúduithe Stáit
State Examinations Commission

JUNIOR CERTIFICATE 2008

MARKING SCHEME

MATHEMATICS

ORDINARY LEVEL

PAPER 2

GENERAL GUIDELINES FOR EXAMINERS

1. Penalties of three types are applied to candidates' work as follows:

- Blunders - mathematical errors/omissions (-3)
- Slips- numerical errors (-1)
- Misreadings (provided task is not oversimplified) (-1).

Frequently occurring errors to which these penalties must be applied are listed in the scheme. They are labelled: B1, B2, B3,..., S1, S2,..., M1, M2,...etc. These lists are not exhaustive.

2. When awarding attempt marks, e.g. Att(3), note that

- any *correct, relevant* step in a part of a question merits at least the attempt mark for that part
- if deductions result in a mark which is lower than the attempt mark, then the attempt mark must be awarded
- a mark between zero and the attempt mark is never awarded.

3. Worthless work is awarded zero marks. Some examples of such work are listed in the scheme and they are labelled as W1, W2,...etc.

4. The phrase “hit or miss” means that partial marks are not awarded – the candidate receives all of the relevant marks or none.

5. The phrase “and stops” means that no more work is shown by the candidate.

6. Special notes relating to the marking of a particular part of a question are indicated by an asterisk. These notes immediately follow the box containing the relevant solution.

7. The sample solutions for each question are not intended to be exhaustive lists – there may be other correct solutions.

8. Unless otherwise indicated in the scheme, accept the best of two or more attempts – even when attempts have been cancelled.

9. The *same* error in the *same* section of a question is penalised *once* only.

10. Particular cases, verifications and answers derived from diagrams (unless requested) qualify for attempt marks at most.

11. A serious blunder, omission or misreading results in the attempt mark at most.

12. Do not penalise the use of a comma for a decimal point, e.g. €5.50 may be written as €5,50.

QUESTION 1

Part (a)	10 marks	Att 3
Part (b)	25(10,10,5) marks	Att 8(3,3,2)
Part (c)	15(5,5,5) marks	Att 6(2,2,2)

Part (a) **10 marks** **Att 3**

Add 430 cm to 179 cm and give your answer in metres.

(a) **10 marks** **Att 3**

$$\begin{array}{l} \text{✍} \quad 430 + 179 = 609\text{cm} \\ \quad \quad \frac{609}{100} \\ \\ \quad \quad 6.09\text{m} \end{array}$$

* Accept “,” for decimal point if used throughout the paper.

Blunders (-3)

- B1 Correct answer without work ✍
- B2 Incorrect conversion or no conversion
- B3 Incorrect mathematical operation with work and continues correctly e.g. multiplies instead of adds.
- B4 Decimal error
- B5 $430 + 179 = 609 = 6 \text{ m } 9 \text{ cm}$ and stops

Slips (-1)

- S1 Numerical slips to a maximum of -3
- S2 Leaves answer as $\frac{609}{100}$

Attempts (3 marks)

- A1 Some correct step with work.
- A2 Converts one or both to metres correctly and stops e.g. 4.30m
- A3 States $100\text{cm} = 1\text{m}$ and stops.
- A4 Some correct effort at conversion and stops e.g. $\frac{430}{100}$.
- A5 609 without work and stops
- A6 $430 + 179$ and stops.

Worthless (0)

- W1 Incorrect answer without work unless attempt mark applies.

Part (b)

25(10, 10, 5) marks

Att 8(3, 3, 2)

A bus leaves Sligo at 11:45 and arrives in Derry at 14:15.

(b)(i)

10 marks

Att 3

How long does the bus journey take?

Give your answer in hours and minutes.



$$\begin{aligned} 14:15 - 11:45 \\ = 2:30 \end{aligned}$$

or

$$\begin{aligned} 13:75 - 11:45 \\ = 2:30 \end{aligned}$$

- * Accept answer in twelve hour clock format.
- * Do not penalise the same error twice in part (b)

Blunders (-3)

- B1 Correct answer without work
- B2 Incorrect mathematical operation with work and continues.
- B3 Error in converting hours to minutes or no conversion.
- B4 Incorrectly converts to a twelve hour format and continues.

Slips (-1)

- S1 Numerical slips to a maximum of -3

Attempts (3 marks)

- A1 Some correct step with work
- A2 States 1 hour = 60 minutes and stops.
- A3 Writes $11:45 - 14:15 = 3:30$

Worthless (0)

- W1 Incorrect answer without work unless attempt mark applies e.g. 3:10

(b)(ii)

10 marks

Att 3

The bus travels a distance of 135 km.

Calculate the average speed, in km/h, for the journey from Sligo to Derry

 2 hours 30 minutes = 2.5 hours

$$\begin{aligned}\text{Average Speed} &= \frac{D}{T} \\ &= \frac{135}{2.5} \\ &= 54\end{aligned}$$

- * Accept candidates answer in part (i)
- * Accept ratio method.

Blunders (-3)

- B1 Correct answer without work 
- B2 Incorrect relevant formula.
- B3 Error in converting hours to minutes or no conversion (unless penalised in part (i)).
- B4 No division.
- B5 Decimal error

Slips (-1)

- S1 Numerical slips to a maximum of -3

Attempts (3 marks)

- A1 Some correct step with work e.g. 2 hours 30 minutes = 2.5 hours
- A2 States 1 hour = 60 minutes and stops.
- A3 Correct formula and stops.

Worthless (0)

- W1 Incorrect answer without work unless attempt mark applies.

(b)(iii)

5 marks

Att 2

The bus uses 1 litre of diesel for every 4.5 km travelled.
On a particular day, diesel cost 115.9 cent per litre.
Find the cost of the diesel used by the bus on that day
for the journey from Sligo to Derry.
Give your answer correct to the nearest euro.



$$\begin{aligned} \text{No. of litres required} &= \frac{135}{4.5} = 30 \\ \text{Cost} &= 30 \times 115.9 \\ &= 3477 \text{ or } 34.77 \\ &= \text{€}35 \end{aligned}$$

Blunders (-3)

- B1 Correct answer without work
- B2 Incorrect mathematical operation with work and continues.
- B3 Decimal error.
- B4 Mathematical Error

Slips (-1)

- S1 Numerical slips to a maximum of -3
- S2 Incorrect round off or no round off.

Attempts (2 marks)

- A1 Some correct step with work e.g. $\frac{135}{4.5}$ and stops.
- A2 Answer given as 30 with or without work and stops.
- A3 Writes 135×115.9 or 4.5×115.9 and stops.

Worthless (0)

- W1 Incorrect answer without work unless attempt mark applies.

Part (c)

15 (5, 5, 5) marks

Att 6(2, 2, 2)

An athletics track has two equal parallel sides $[pq]$ and $[sr]$ and two equal semi-circular ends with diameters $[ps]$ and $[qr]$.
 $|pq| = |sr| = 153$ metres, and $|ps| = |qr| = 30$ metres.

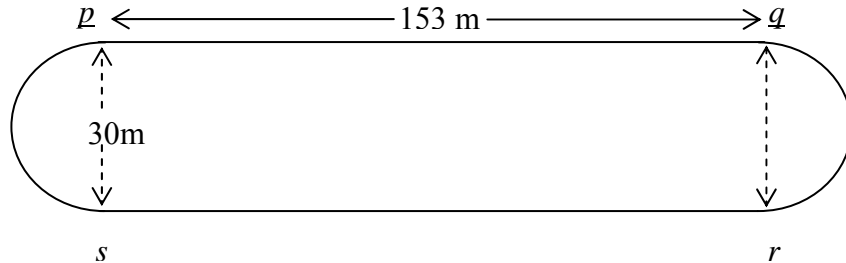

(c)(i)

5 marks

Att 2

Taking π as 3.14 , calculate the length of one of the semi-circular ends, correct to the nearest metre.



$$\begin{aligned} \text{Length} &= \pi r \\ &= 3.14 \times 15 \\ &= 47.1 \\ &= 47\text{m} \end{aligned}$$

Blunders (-3)

- B1 Correct answer without work
- B2 Incorrect mathematical operation with work and continues.
- B3 Incorrect relevant formula e.g. $2\pi r$ or πr^2
- B4 Incorrect substitution and continues e.g. $r = 30$.
- B5 $\pi \neq 3.14$ or answer given in terms of π
- B6 Decimal Error

Slips (-1)

- S1 Numerical slips to a maximum of -3.
- S2 Incorrect round off or no round off.

Attempts (2 marks)

- A1 Some correct step with work.
- A2 $r = 15$ and stops or 15 without work.
- A3 Correct formula or $2\pi r$ and stops.

Worthless (0)

- W1 Incorrect answer without work unless attempt mark applies.
- W2 Incorrect formula without work.

(c)(ii)

5 marks

Att 2

Calculate the total length of one lap of the track,
correct to the nearest metre.



$$\begin{aligned} \text{Length} &= 153 + 153 + 47 + 47 \\ &= 400 \text{ m} \end{aligned}$$

* Accept candidates answer from part (i)

Blunders (-3)

- B1 Correct answer without work 
- B2 Incorrect mathematical operation and continues.
- B3 Omits one or more lengths.

Slips (-1)

- S1 Numerical slips to a maximum of -3.
- S2 Fails to add.

Attempts (2 marks)

- A1 Some correct step with work e.g. $153 + 153$ and stops
- A2 Writes 47 and/or 94 and stops
- A3 Recognises 153 as part of the answer e.g. $153 + \dots$ and stops or 153 on its own.

Worthless (0)

- W1 Incorrect answer without work unless attempt mark applies.

(c)(iii)

5 marks

Att 2

Noirín ran a 5000 metre race on the above track in 15 minutes.
Calculate, in seconds, the average time it took Noirín to complete
one lap of the track during that race.



1 metre in $\frac{15}{5000}$	$\frac{5000}{400} = 12.5$
400 metres in $\frac{15}{5000} \times 400$ = 1.2 minutes = 72 seconds.	$\frac{15}{12.5} \times 60 = 72$ seconds

* Accept candidates answers from part (ii).

Blunders (-3)

- B1 Correct answer without work
- B2 Incorrect mathematical operation and continues.
- B3 Decimal error.
- B4 Fails to convert to seconds or converts incorrectly.

Slips (-1)

- S1 Numerical slips to a maximum of -3.

Attempts (2 marks)

- A1 Some correct step with work.
- A2 States 1minute = 60 seconds.
- A3 Writes $\frac{15}{5000}$ and stops.

Worthless (0)

- W1 Incorrect answer without work unless attempt mark applies.

QUESTION 2

Part (a)	10 marks	Att 3
Part (b)	20(15,5) marks	Att 7(5,2)
Part (c)	20(10,5,5) marks	Att 7(3,2,2)

Part (a) **10 marks** **Att 3**

A disc has a radius of 2.5 cm.

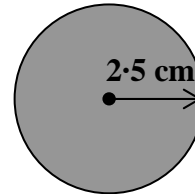

Taking π as 3.14, calculate, in cm^2 , the area of the disc

(a) **10 marks** **Att 3**



$$\begin{aligned}\text{Area of disc} &= \pi r^2 \\ &= 3.14 \times 2.5 \times 2.5 \\ &= 19.625 \text{ cm}^2\end{aligned}$$

Blunders (-3)

- B1 Correct answer without work 
- B2 Incorrect substitution and continues correctly
- B3 Mathematical error e.g. $(2.5)^2 = 5$
- B4 Incorrect relevant formula and continues e.g. $2\pi r$ or a multiple of πr^2
- B5 $\pi \neq 3.14$ or answer in terms of π .
- B6 Decimal Error

Slips (-1)

- S1 Numerical slips to a maximum of -3

Attempts (3 marks)

- A1 Some correct step with work and stops e.g. πr^2
- A2 3.14×2.5 with or without answer of 7.85.
- A3 Writes $(2.5)^2$ and stops.

Worthless (0)

- W1 Incorrect answer without work unless attempt mark applies.

Part (b)

20 marks (15, 5)

Att 7 (5, 2)

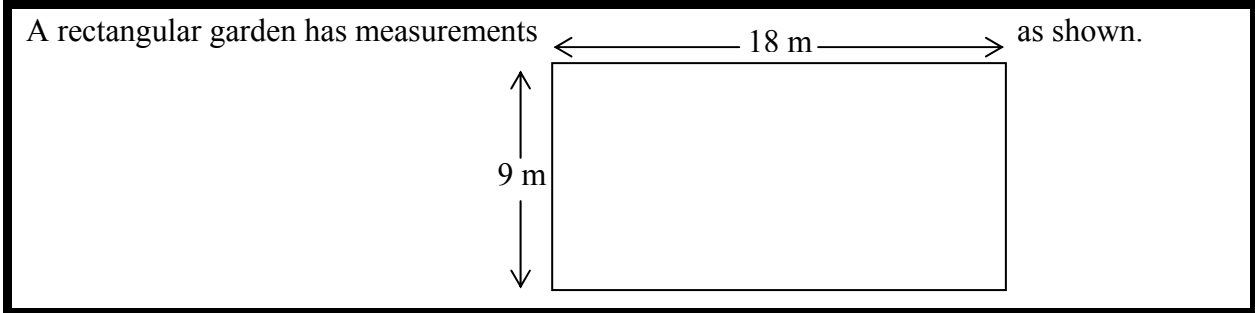

(b)(i)

15 marks

Att 5

Find, in m^2 , the area of the garden.

 Area = $18 \times 9 = 162 m^2$

Blunders (-3)

- B1 Correct answer without work 
- B2 Incorrect substitution or omission or extra, each time and continues.
- B3 Incorrect mathematical operation and continues.
- B4 Incorrect relevant formula and continues.
- B5 Correctly finds the perimeter and continues.

Slips (-1)

- S1 Numerical slips to a maximum of -3
- S2 Leaves answer as 18×9

Attempts (5 marks)

- A1 Some correct step with work and stops.
- A2 Correct formula e.g. $L \times B$ and stops.

Worthless (0)

- W1 Incorrect answer without work unless attempt mark applies.
- W2 Use of formula involving π
- W3 $L \times L$ and stops.

(b)(ii)

5 marks

Att 2

The garden is to be covered completely with square concrete slabs each of side 50 cm .
Find the number of slabs required to cover the garden



Area of one slab	=	0.5×0.5	=	$0.25 m^2$	or	36×18
Area of garden				$= 162 m^2$		$= 648$
Number of slabs		$= \frac{162}{0.25}$		$= 648.$		

* Accept candidates answer from part (i).

Blunders (-3)

- B1 Correct answer without work
- B2 Mathematical error
- B3 Incorrect relevant formula and continues
- B4 Incorrect mathematical operation and continues e.g. $162 \times 0.25 = 40.5$
- B5 Decimal error.

Slips (-1)

- S1 Numerical slips to a maximum of -3

Attempts (2 marks)

- A1 Some correct step with work and stops.
- A2 Correct formula for area of square or rectangle and stops.
- A3 Converts 50cm to metres correctly and stops.
- A4 Writes 162 or candidates answer from part (i) and stops.
- A5 Writes 36 and / or 18 and stops.
- A6 Writes $\frac{162 \times 100}{50}$ with or without answer
- A7 Writes $\frac{162}{0.5}$ with or without answer.

Worthless (0)

- W1 Incorrect answer without work unless attempt mark applies.
- W2 Use of formula involving π

Part (c)

20 marks (10, 5, 5)

Att 7 (3, 2, 2)

(c)(i)

10 marks

Att 3

A rectangular carton full of orange juice measures 10 cm by 7 cm by 25 cm.
Find, in cm^3 , the volume of orange juice in the carton

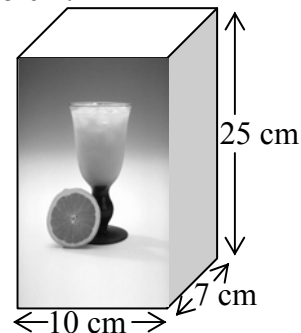

$$\begin{aligned}\text{Volume} &= 10 \times 7 \times 25 \\ &= 1750 \text{ cm}^3\end{aligned}$$

Blunders (-3)

- B1 Correct answer without work 
- B2 Incorrect substitution or omission or extra, each time and continues.
- B3 Mathematical error
- B4 Incorrect relevant formula and continues e.g. surface area and continues.
- B5 Leaves answer as $10 \times 7 \times 25$

Slips (-1)

- S1 Numerical slips to a maximum of -3

Attempts (3 marks)

- A1 Some correct step with work and stops.
- A2 Correct formula for volume of rectangular solid and stops.
- A3 Writes $10 + 7 + 25 = 42$

Worthless (0)

- W1 Incorrect answer without work unless attempt mark applies.
- W2 Use of formula involving π
- W3 Writes $10 + 7 + 25$ and stops.
- W4 Writes 42 without work

(c)(ii)

5 marks

Att 2

The orange juice fills 14 cylindrical glasses exactly.
Find, in cm^3 , the volume of each glass



$$\begin{aligned}\text{Volume of glass} &= \frac{1750}{14} \\ &= 125 \text{ cm}^3\end{aligned}$$

* Accept candidates answer from part (i)

Blunders (-3)

B1 Correct answer without work

B2 Incorrect mathematical operation and continues e.g 1750×14

Slips (-1)

S1 Numerical slips to a maximum of -3

S2 $\frac{1750}{14}$ and stops.

Attempts (2 marks)

A1 Some correct step with work and stops

A2 Writes 1750 and stops.

Worthless (0)

W1 Incorrect answer without work unless attempt mark applies.

(c)(iii)

5 marks

Att 2

The radius of each glass is 2.4 cm. Taking π as 3.14, calculate the height of each glass, correct to the nearest cm.



$$\begin{aligned} \pi r^2 h &= 125 \\ (3.14)(2.4)(2.4)(h) &= 125 \\ h &= \frac{125}{(3.14)(2.4)(2.4)} \\ &= 6.91 \\ &= 7 \text{ cm} \end{aligned}$$

* Accept candidates answer from part (ii)

Blunders (-3)

- B1 Correct answer without work 
- B2 Incorrect relevant cylinder formula with work e.g. $2\pi r h$.
- B3 Incorrect substitution.
- B4 Mathematical error
- B5 Transposition error
- B6 $\pi \neq 3.14$ or answer given in terms of π

Slips (-1)

- S1 Numerical slips to a maximum of -3
- S2 Incorrect round off or no round off.

Attempts (2 marks)

- A1 Some correct step with work and stops.
- A2 A correct substitution and stops.
- A3 Use of the answer from part (ii) e.g. $\frac{125}{2.4}$

Worthless (0)

- W1 Incorrect answer without work unless attempt mark applies.

QUESTION 3

Part (a)	10 marks	Att 3
Part (b)	20 (10,5,5) marks	Att 7(3,2,2)
Part (c)	20 (10,5,5) marks	Att 7 (3,2,2)

Part (a) **10 marks** **Att 3**

Find the mode of the numbers: 11, 6, 8, 6, 11, 4, 6, 3, 8.

Mode = 6

* Accept correct answer without work.

Blunders (-3)

- B1 Gives 3 as the mode with explanation e.g. "because 6 occurs 3 times"
- B2 Finds mean of the given numbers e.g. 7

Attempts (3 marks)

- A1 Some correct step and stops.
- A2 Writes, "mode means most".
- A3 Writes $11 + 6 + 8 + 6 + 11 + 4 + 6 + 3 + 8$ and / or 63 and stops.
- A4 Writes 9 or 3 or 63 and stops.
- A5 Rearranges the numbers in order and stops.

Worthless (0)

- W1 Incorrect answer without work unless attempt mark or B2 applies.
- W2 Just a list of numbers e.g. 6, 1, 5..

Part (b)

20 marks (10, 5, 5)

Att 7 (3, 2, 2)

A group of people was surveyed to find which country was their preferred holiday destination+ The pie chart represents the result of that survey

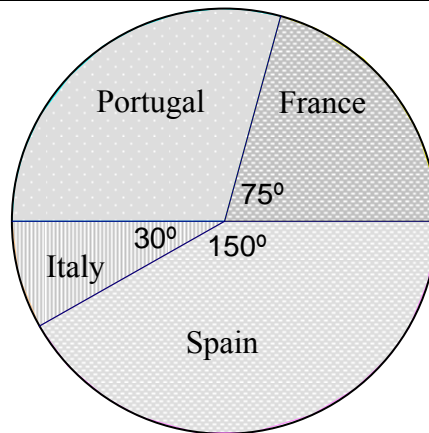

(b)(i)

10 marks

Att 3

What is the measure of the angle for Portugal?



$$\begin{array}{l} 75 + 150 + 30 = 255 \\ 360 - 255 \\ 105 \end{array} \quad \text{or} \quad \begin{array}{l} 180 - 75 \\ 105 \end{array}$$

* Do not penalise the same error twice in part (b)

Blunders (-3)

- B1 Correct answer without work
- B2 Angle at centre of circle $\neq 360^\circ$
- B3 Straight line angle $\neq 180^\circ$
- B4 Each angle omitted.

Slips (-1)

- S1 Numerical slips to a maximum of -3
- S2 Writes $360 - 255$ or $180 - 75$ and stops

Attempts (3 marks)

- A1 Some correct step with work and stops e.g. $75 + 30 = 105$
- A2 States "Straight line = 180° " or similar and stops
- A3 States "Angle at centre of circle = 360° " or similar and stops.
- A4 Writes 255 and stops.

Worthless (0)

- W1 Incorrect answer without work unless attempt mark applies.

(b)(ii)

5 marks

Att 2

10 people replied that Italy was their favourite holiday destination
How many people were surveyed?

$\begin{aligned} \text{✍} \quad 30^\circ &= 10 \\ 1^\circ &= \frac{10}{30} \\ 360^\circ &= \frac{10}{30} \times 360 \\ &= 120 \end{aligned}$	<p>or</p> $\begin{aligned} 30^\circ &= \frac{1}{12} \text{ of } 360 \\ 12 \times 10 &= 120 \end{aligned}$
--	---

Blunders (-3)

- B1 Correct answer without work ✍
- B2 Incorrect ratio
- B3 Mathematical error
- B4 Decimal error.

Slips (-1)

- S1 Numerical slips to a maximum of -3
- S2 12×10 and stops

Attempts (2 marks)

- A1 Some relevant step with work
- A2 Writes 30° or 360° and / or $\frac{1}{12}$ or $\frac{1}{3}$ and stops

Worthless (0)

- W1 Incorrect answer without work unless attempt mark applies.

(b)(iii)

5 marks

Att 2

How many gave Spain as their reply?

$\frac{150}{360} \times 120$	<u>or</u>	$30^\circ = 10$
$= 50$		$150^\circ = 10 \times 5$
		$= 50$

* Accept candidates answer in part (ii)

Blunders (-3)

- B1 Correct answer without work 
- B2 Incorrect ratio
- B3 Mathematical error.
- B4 Decimal error.

Slips (-1)

- S1 Numerical slips to a maximum of -3.
- S2 Writes 10×5 and stops.
- S3 Early round off.

Misreading (-1)

- M1 Gives correct answer for France or Portugal with work e.g. 25 or 35.

Attempts (2 marks)

- A1 Some correct step with work and stops
- A2 Writes 150, 360 or 120 and stops.

Worthless (0)

- W1 Incorrect answer without work unless attempt mark applies.

Part (c)

20 marks (10, 5, 5)

Att 7 (3, 2, 2)

At the end of a month 50 students wrote down the number of days they were absent from school during that particular month.

The results are shown in the following table:

Number of days absent	0	1	2	3	4	5
Number of students	12	7	12	10	6	3

(c)(i)

10 marks

Att 3

Draw a bar chart of the data.

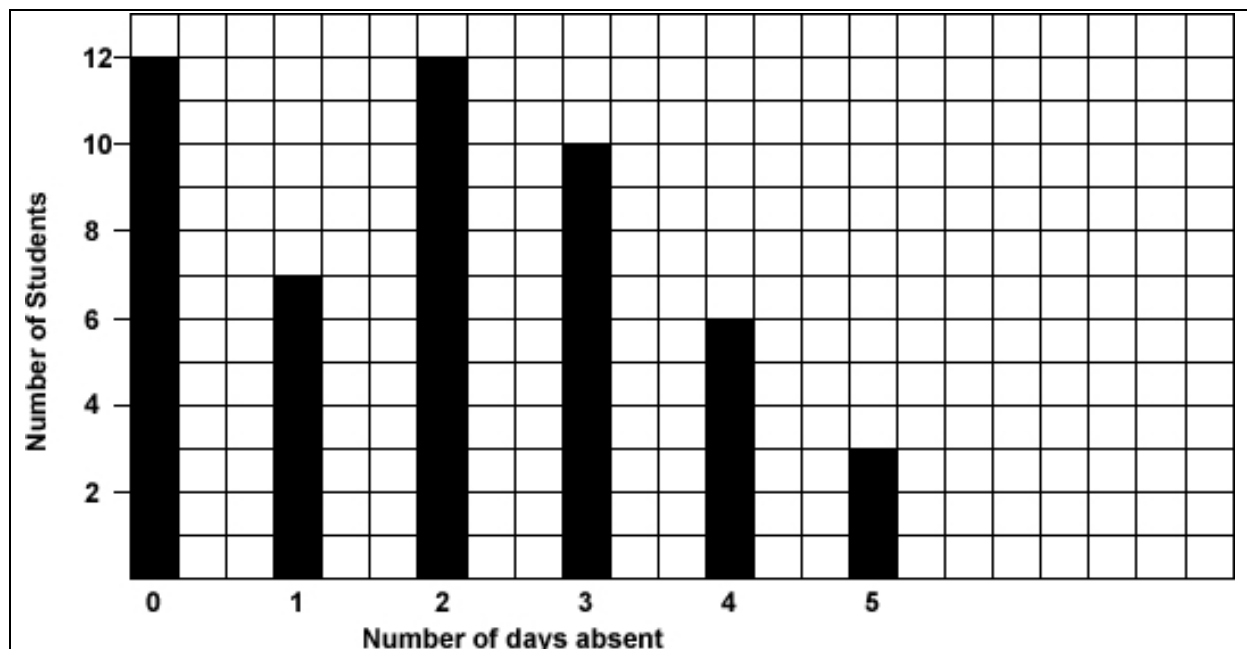

- * Accept correct graph with no labels.
- * Accept horizontal or vertical bar chart
- * Accept bars of unequal widths or bars joined as a histogram
- * Accept lines as bars

Blunders (-3)

- B1 Axis with student numbers not graduated uniformly.
- B2 Reverse variable and frequency when drawn.
- B3 Draws a trend graph or pie chart.

Slips (-1)

- S1 Each incorrect bar or bar omitted to a max of -3.

Attempts (3 marks)

- A1 Graduated axis or axes only.

Find the mean number of days absent per student.



$$\begin{aligned}
 \text{Mean} &= \frac{\sum fx}{\sum f} \\
 &= \frac{(0 \times 12) + (1 \times 7) + (2 \times 12) + (3 \times 10) + (4 \times 6) + (5 \times 3)}{12 + 7 + 12 + 10 + 6 + 3} \\
 &= \frac{0 + 7 + 24 + 30 + 24 + 15}{50} \\
 &= \frac{100}{50} \\
 &= 2
 \end{aligned}$$

Blunders (-3)

- B1 Correct answer without work
- B2 Incorrect mathematical operation in numerator or denominator.
- B3 Incorrect denominator or no denominator e.g. $\frac{100}{12}$
- B4 Inverted fraction.
- B5 Frequencies omitted in numerator
- B6 Omits 2 or more values in numerator.

Slips (-1)

- S1 Numerical slips to a maximum of -3.
- S2 $\frac{100}{50}$ and stops.
- S3 Omits one value in numerator with work.

Attempts (2 marks)

- A1 Some correct step with work and stops e.g. $12 + 7 + 12 + 10 + 6 + 3$ and/or 50.
- A2 Mean = $\frac{\sum fx}{\sum f}$ and stops.
- A3 A relevant multiplication and stops.
- A4 Average of the frequencies e.g. $\frac{12 + 7 + 12 + 10 + 6 + 3}{6} = \frac{50}{6}$
- A5 $\frac{0 + 1 + 2 + 3 + 4 + 5}{6} = \frac{15}{6}$.
- A6 100 or 50 without work.

Worthless (0)

- W1 Incorrect answer without work unless attempt mark applies.

Find the percentage of students who were absent for three or more days.



$$\text{Number of students absent} = 10 + 6 + 3 = 19$$

$$\begin{aligned}\text{Percentage} &= \frac{19}{50} \times 100 \\ &= 38 \%\end{aligned}$$

Blunders (-3)

- B1 Correct answer without work 
- B2 Incorrect mathematical operation.
- B3 Omits the 100 or divides by the 100.
- B4 Omits an entry or inserts an incorrect entry in the addition
- B5 Leave answer as $\frac{19}{50} \times 100$
- B6 Decimal error

Slips (-1)

- S1 Numerical slips to a maximum of -3.
- S2 Writes 19×2 and stops.

Attempts (2 marks)

- A1 Some correct step with work and stops e.g. indicates the 100.
- A2 Writes any of the following numbers; 10, 6, 3, 19, 50, 100.

Worthless (0)

- W1 Incorrect answer without work unless attempt mark applies.

QUESTION 4

Part (a)	10 marks	Att 3
Part (b)	25 (10,5,5,5) marks	Att 9(3,2,2,2)
Part (c)	15 (5,5,5) marks	Att 6(2,2,2)

Part (a) **10 marks** **Att 3**

L and M are parallel lines.
Find the value of x and the value of y
in the diagram

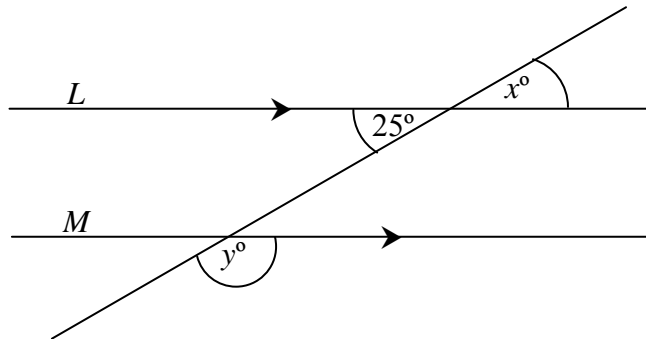

$$x = 25^\circ$$

$$y = 180 - 25 \\ 155^\circ$$

* Accept correct answer marked / indicated on a diagram

* Accept correct answer without work

Blunders (-3)

B1 Straight line angle $\neq 180^\circ$

B2 Finds one value only

B3 Writes $x = 155^\circ$ and $y = 25^\circ$

Slips (-1)

S1 Numerical slips to a maximum of -3.

Attempts (3 marks)

A1 Some correct step and stops e.g. 180° .

A2 States "Straight line angle = 180° " or similar and stops.

A3 States "Vertically opposite angles are equal" or similar and stops.

A4 Uses an arbitrary value for x or y with relevant work.

A5 $y = 25^\circ$.

A6 $x = 155^\circ$.

Worthless (0)

W1 Incorrect answer without work unless attempt mark applies.

Part (b)

25 marks (10, 5, 5, 5)

Att 9 (3, 2, 2, 2)

pqr is an isosceles triangle with $|rp| = |rq|$, $rs \perp pq$ and $|\angle rpq| = 65^\circ$

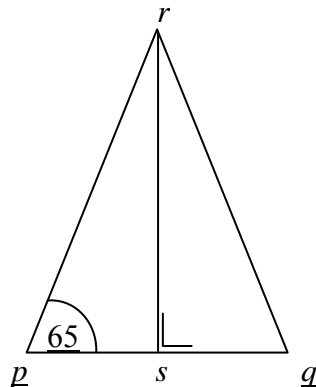

(b)(i)

10 marks

Att 3

Find $|\angle pqr|$ and give a reason for your answer

$$|\angle pqr| = 65^\circ$$

Reason: Base angles in an isosceles triangle are equal

* Accept correct answer marked / indicated on a diagram

* Accept correct answer without work

Blunders (-3)

B1 States $|\angle rpq| = 65^\circ$ and continues to get $|\angle pqr| = 50^\circ$

B2 Sum of angles in a triangle $\neq 180^\circ$

B3 Correct answer without a reason or with an incorrect reason.

Attempts (3 marks)

A1 Some correct step with work and stops e.g. Finds $|\angle prs| = 25^\circ$

A2 Indicates clearly $\angle pqr$ on the diagram

A3 Marks $|rp| = |rq|$ on the diagram.

A4 Correct reason only given.

Worthless (0)

W1 Incorrect answer without work unless attempt mark applies.

W2 Diagram reproduced without modification.

(b)(ii)

5 marks

Att 2

Find $|\angle prq|$.

$$|\angle prq| = 180 - 65 - 65 = 50^\circ \quad \text{or} \quad \angle prq = 2\angle prs = 2(90 - 65) = 2(25) = 50^\circ$$

* Accept correct answer marked / indicated on a diagram

* Accept correct answer without work

* Accept candidates answer from part (i)

Blunders (-3)

B1 Sum of angles in a triangle $\neq 180^\circ$

B2 Mathematical error.

Attempts (2 marks)

A1 Some correct step and stops e.g. 180° or 25° or 90° or 130° .

A2 States "Sum of angles in a triangle = 180° " or similar.

A3 Clearly indicates $\angle prq$ on a diagram drawn in answer box.

Worthless (0)

W1 Incorrect answer without work unless attempt mark applies.

W2 Diagram reproduced without modification.

(b)(iii)

5 marks

Att 2

Given that $|pq| = 5.8$ cm and $|rs| = 6.2$ cm,
find the area of the Δpqr in cm^2 .

$$\begin{aligned} \text{Area} &= \frac{1}{2}(\text{base})(\text{height}) \\ &= \frac{1}{2}(5.8)(6.2) \\ &= \frac{1}{2}(35.96) \\ &= 17.98 \text{ cm}^2 \end{aligned}$$

Blunders (-3)

- B1 Correct answer without work 
- B2 Incorrect relevant formula and continues e.g. $\frac{1}{2}$ omitted
- B3 Incorrect mathematical operation
- B4 Decimal error.

Slips (-1)

- S1 Numerical slips to a maximum of -3.

Attempts (2 marks)

- A1 Some correct step with work and stops .
- A2 Correct formula for area of triangle and stops.
- A3 Writes 5.8×6.2 and stops.
- A4 Indicates on diagram $|pq| = 5.8$ and/or $|rs| = 6.2$ in this answer box.

Worthless (0)

- W1 Incorrect answer without work unless attempt mark applies.
- W2 Diagram reproduced without modification.

(b)(iv)

5 marks

Att 2

Show that Δprs and Δqrs are congruent.

	$ rp = rq $	or	$ \angle rpq = \angle rqp $	or	$ rp = rq $
	$ rs = rs $ common side.		$ rp = rq $		$ \angle prs = \angle qrs $
	$ \angle rsp = \angle rsq $		$ \angle prs = \angle qrs $		$ rs = rs $

* Accept correct answer marked or indicated on a diagram.

Blunders (-3)

B1 Each step omitted.

Attempts (2 marks)

A1 Some correct step with work and stops.

A2 States same shape or SSS or ASA or SAS or RHS.

A3 States triangles fold onto each other.

A4 Clearly indicates the two required triangles in the answer box for this part.

Worthless (0)

W1 Diagram reproduced without modification.

Part (c)

15 marks (5, 5, 5)

Att 8 (2, 2, 2)

a, b, c and x are points on a circle with centre o .

as shown. $|\angle bac| = 30^\circ$, $|\angle cbe| = w^\circ$.

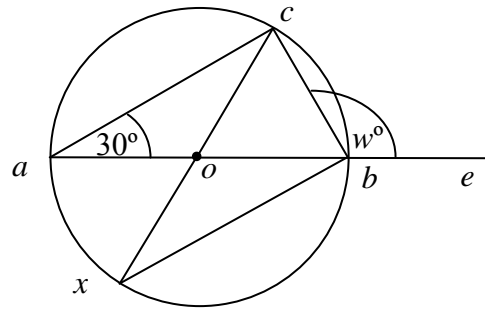

(c)(i)

5 marks

Att 2

Name the image of Δaoc under S_o , the central symmetry in o .

Δbox

- * Accept Δbox with points in any order.
- * Accept $a \rightarrow b$, $o \rightarrow o$ and $c \rightarrow x$.
- * Accept diagram with correct indication / shading.

Blunders (-3)

B1 Each point whose image is not found (or incorrectly found).

Attempts (2 marks)

- A1 Some correct step with work and stops.
- A2 Shows some knowledge of central symmetry and stops.
- A3 States that the image is a triangle.
- A4 Finds the image of one or two points correctly e.g. $o \rightarrow o$ or $ao \rightarrow ox$
- A5 If b, o or x appears in any group of letters.

Worthless (0)

W1 Diagram reproduced without modification.

(c)(ii)

5 marks

Att 2

Find the value of w .

$$\begin{aligned}30 + 90 + |\angle abc| &= 180^\circ \\|\angle abc| &= 180 - 120 \\|\angle abc| &= 60^\circ \\180 &= 60 + w \\120 &= w\end{aligned}$$

Blunders (-3)

- B1 Correct answer without work 
- B2 Straight line angle $\neq 180^\circ$.
- B3 Transposition error.
- B4 Error in finding $|\angle abc|$
- B5 Sum of angles in triangle $\neq 180^\circ$

Slips (-1)

- S1 Numerical slips to a maximum of -3.
- S2 $180 - 60$ and stops.

Attempts (2 marks)

- A1 Some correct step with work and stops.
- A2 Writes down or indicates that $|\angle acb| = 90^\circ$.
- A3 States “angles in a straight line = 180° ” or similar and stops.
- A4 States “sum of 3 angles in a triangle = 180° ” or similar and stops.
- A5 Writes $30 + 90$ and stops.
- A6 $180 - 30$ or $180 - 90$ or 180 and stops.

Worthless (0)

- W1 Incorrect answer without work unless attempt mark applies
- W2 Diagram reproduced without modification.

(c)(iii)

5 marks

Att 2

$pqrs$ is a cyclic quadrilateral of the circle K

$$|\angle spq| = 82^\circ \text{ and } |\angle srq| = z^\circ.$$

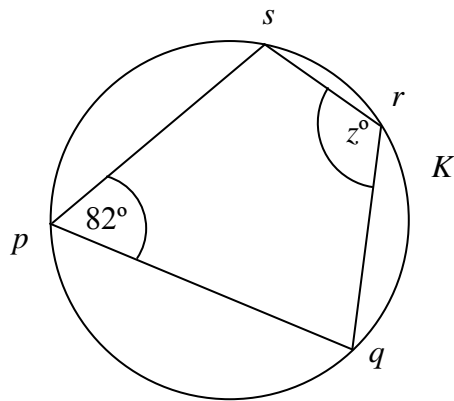

Find the value of z .

$$z = 180 - 82 = 98^\circ$$

* Accept correct answer marked / indicated on a diagram

* Accept correct answer without work

Blunders (-3)

B1 Opposite angles $\neq 180^\circ$

Slips (-1)

S1 Numerical slips to a maximum of -3.

S2 Writes $180 - 82$ and stops.

Attempts (2 marks)

A1 Some correct step with work and stops.

A2 States "opposite angles of cyclic quadrilateral = 180° " or similar and stops.

A3 Writes 180° or 360° or 164° and stops.

Worthless (0)

W1 Incorrect answer without work unless attempt mark applies

W2 Diagram reproduced without modification.

QUESTION 5

Part (a)	10 marks	Att 3
Part (b)	25 (10,10,5) marks	Att 8(3,3,2)
Part (c)	15 (10,5) marks	Att 5(3,2)

Part (a) **10 marks** **Att 3**

Write down the coordinates
of the point *a*.

b.

$a = (3, -2)$

- * Accept without brackets for full marks e.g. 3,-2
- * Accept $x = 3$ and $y = -2$ for full marks.

Blunders (-3)

- B1 Incorrect order in couple (-2,3) .
- B2 Incorrect x ordinate, if not sign error, subject to B1.
- B3 Incorrect y ordinate, if not sign error, subject to B1.
- B4 $x = 3$ and stops or $y = -2$ and stops

Slips (-1)

- S1 Sign error in x ordinate.
- S2 Sign error in y ordinate.

Attempts (3 marks)

- A1 Draws a line through 3 and / or -2

Worthless (0)

- W1 3 on its own with no work
- W2 -2 on its own with no work

Notes:

- | | | |
|-----------|---------------|----------------|
| (3,4): B3 | (-3,2): S1,S2 | (2,3): B2,B3 |
| (3,0): B3 | (0,2): S1,B2 | (-2,-3): B2,B3 |
| (3,2): S2 | (4,4): B2,B3 | (-2,3): B1 |

p is the point (1, 2) and q is the point (5, -8). Find each of the following:

(b)(i)

10 marks

Att 3

the midpoint of $[pq]$

$$\begin{aligned} & \left(\frac{1+5}{2}, \frac{2-8}{2} \right) \\ & = \left(\frac{6}{2}, \frac{-6}{2} \right) \\ & = (3, -3) \end{aligned}$$

- * Accept translation method.
- * No penalty on brackets.

Blunders (-3)

B1 Correct answer without work ~~✗~~

B2 Incorrect formula e.g. error in both signs $\left(\frac{x_1 - x_2}{2}, \frac{y_1 - y_2}{2} \right)$ or $\left(\frac{x_1 + y_1}{2}, \frac{x_2 + y_2}{2} \right)$ or $\left(\frac{x_1 + x_2}{2} + \frac{y_1 + y_2}{2} \right)$ or omits the divisor 2 and continues.

B3 Incorrectly treats couples as (x_1, x_2) and (y_1, y_2) and continues.

B4 Two or more signs incorrect in substitution and continues.

B5 Reversal of coordinates i.e. (-3, 3) with work.

B6 One ordinate only worked out correctly.

B7 Uses one of the given points and some arbitrary point e.g. (1, 2) and (0,0) and continues.

B8 Mathematical error e.g. Sign rules

Slips (-1)

S1 Numerical slips to a maximum of -3.

S2 Error in one sign in midpoint formula and continues.

S3 One incorrect substitution or sign when substituting e.g. $\left(\frac{1+5}{2}, \frac{2+8}{2} \right)$ and continues

S4 Takes (1,2) as midpoint and finds extremity e.g. $(5, -8) \rightarrow (1, 2) \rightarrow (-3, 12)$ or takes (5,-8) as midpoint and finds extremity e.g. $(1, 2) \rightarrow (5, -8) \rightarrow (9, -18)$

Attempts (3 marks)

A1 Some correct substitution

A2 Correct midpoint indicated on graph and not named (if named B1 applies)

A3 Point p and / or q plotted reasonably well for this part.

A4 Labels p and / or q with (x_1, y_1) and stops.

A5 Identifies (x_1, y_1) and/or (x_2, y_2) (for this part).

Worthless (0)

W1 Use wrong formula e.g. slope or distance formula.

W2 Writes midpoint formula and stops.

 (ii) the slope of pq

 $\left(\frac{2+8}{1-5}\right) = \frac{10}{-4}$ or $\frac{-5}{2}$ or -2.5 **OR** $\left(\frac{-8-2}{5-1}\right) = \frac{-10}{4}$ or $\frac{-5}{2}$ or -2.5

* Accept candidates midpoint as a point for finding the slope.

* Accept correct trigonometric method i.e. $\tan \theta = \frac{-5}{2}$.

Blunders (-3)

B1 Correct answer without work .

B2 Incorrect slope formula e.g. $\frac{x_2 - x_1}{y_2 - y_1}$ or $\frac{y_2 + y_1}{x_2 + x_1}$ or $\frac{y_2 - y_1}{x_1 - x_2}$ or $\frac{x_1 - y_1}{x_2 - y_2}$ or $\frac{\text{horizontal}}{\text{vertical}}$
or $\tan \theta = \frac{\text{adjacent}}{\text{opposite}}$ and continues.

B3 Incorrectly treats couples as (x_1, x_2) and (y_1, y_2) if not already penalised e.g. $\frac{5+8}{1-2}$ or $\frac{1-2}{5+8}$

B4 Mathematical error e.g. sign rules.

B5 Uses one of the given point and some arbitrary point e.g. (1, 2) and (0,0) and continues.

B6 Error in more than one sign when substituting.

Slips (-1)

S1 Numerical slips to a maximum of -3.

S2 Error in one sign in slope formula e.g. $\frac{y_2 - y_1}{x_2 + x_1}$.

S3 One incorrect substitution or sign for substituting.

Attempts (3 marks)

A1 Some correct step with work and stops.

A2 $\tan \theta = \frac{\text{opposite}}{\text{adjacent}}$ or $m = \frac{\text{vertical}}{\text{horizontal}}$ and stops.

A3 Some correct substitution into formula with $x_2 - x_1$ and / or $y_2 - y_1$

A4 Points p and / or q plotted reasonably well for this part.

A5 Identifies (x_1, y_1) and / or (x_2, y_2) in this part.

Worthless (0)

W1 Use wrong formula e.g. midpoint formula.

W2 States given formula only.

 (iii) the length of $[pq]$

$ pq $	=	$\sqrt{(1-5)^2 + (2+8)^2}$	$ pq $	=	$\sqrt{(5-1)^2 + (-8-2)^2}$
	=	$\sqrt{(-4)^2 + (10)^2}$		=	$\sqrt{(4)^2 + (-10)^2}$
	=	$\sqrt{(16+100)}$		=	$\sqrt{(16+100)}$
	=	$\sqrt{116}$ or 10.77		=	$\sqrt{116}$ or 10.77

* Accept correct use of Pythagoras.

Blunders (-3)

- B1 Correct answer without work. 
- B2 Incorrect formula e.g. $\sqrt{(x_2 - x_1)^2 - (y_2 - y_1)^2}$ or $\sqrt{(x_2 + x_1)^2 + (y_2 + y_1)^2}$ or omits square root sign or squares and continues.
- B3 Incorrectly treats couples as (x_1, x_2) and (y_1, y_2) if not already penalised.
- B4 Mathematical error e.g. $4^2 = 8$
- B5 Two or more signs in substitution.

Slips (-1)

- S1 Numerical slips to a maximum of -3.
- S2 Error in one sign in $(x_2 - x_1)$ or $(y_2 - y_1)$ in formula.
- S3 One incorrect substitution or sign when substituting.

Attempts (2 marks)

- A1 Some correct step with work.
- A2 Some correct substitution into a formula with $x_2 - x_1$ and/or $y_2 - y_1$
- A3 States theorem of Pythagoras and stops.
- A4 Point p and or q plotted reasonably well (for this part)
- A5 Identifies (x_1, y_1) and/or (x_2, y_2) (for this part).

Worthless (0 marks)

- W1 Use of wrong formula e.g. midpoint formula.
- W2 Incorrect answer without work unless attempt mark applies.

Part (c) (i)

10 Marks

Att 3

The line L contains the point $(2, 1)$
 L has a slope of 3.
 Find the equation of L .



$$y - y_1 = m(x - x_1)$$

$$y - 1 = 3(x - 2)$$

* $1 - y = 3(2 - x)$ or similar merits full marks.

Blunders (-3)

- B1 Correct answer without work.
- B2 Incorrect formula e.g. $y + y_1 = m(x + x_1)$ or $(x - x_1) = m(y - y_1)$ and continues.
- B3 Switches x and y e.g. $y - 2 = 3(x - 1)$
- B4 Mathematical error.
- B5 $y = 3(x + c)$ and stops
- B6 Uses a point other than $(2, 1)$ e.g. $(0, 0)$.
- B7 $m \neq 3$

Slips (-1)

- S1 Numerical slips to a maximum of -3.
- S2 Error in one sign in formula.
- S3 One incorrect substitution or sign when substituting.

Attempts (3 marks)

- A1 Some correct step with work.
- A2 Writes $m = 3$ and stops.
- A3 States $y = mx \pm c$ and stops

Worthless (0 marks)

- W1 Use of wrong formula
- W2 States given formula only.

Note: If an error is made while attempting to simplify this equation, penalise in part (ii)

By letting $y = 0$, find the coordinates of p , the point of intersection of the line L and the x -axis.



$$y-1 = 3(x-2)$$

$$0-1 = 3x-6$$

$$5 = 3x$$

$$\frac{5}{3} = x$$

$$p = \left(\frac{5}{3}, 0\right) \text{ or } \left(1\frac{2}{3}, 0\right)$$

- * Accept candidates answer from part (i)
- * Accept answer given as $x = \frac{5}{3}$ with work shown for full marks.

Blunders (-3)

- B1 Correct answer without work.
- B2 Substitutes $x = 0$ and continues.
- B3 Mathematical error.
- B4 Incorrect substitution and continues.
- B5 Transposition error

Slips (-1)

- S1 Numerical slips to a maximum of -3.

Attempts (2 marks)

- A1 Some correct step with work and stops.
- A2 Substitutes $y = 0$ and stops.
- A3 Writes $y - 1 = 3(x - 2)$ and stops.
- A4 Writes answer as $(x, 0)$ without work where x is an arbitrary number subject to B1.

Worthless (0)

- W1 Incorrect answer with no work unless attempt mark applies.

QUESTION 6

Part (a)	15 (10,5) marks	Att 5(3,2)
Part (b)	20 (10,5,5) marks	Att 7(3,2,2)
Part (c)	15 (10,5) marks	Att 5(3,2)

Part (a) **15 marks (10, 5)** **Att 5 (3, 2)**

The right-angled triangle abc has measurements as shown.

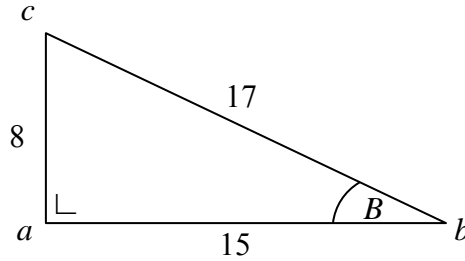

Part (a) (i) **10 Marks** **Att 3**

Write down the length of the hypotenuse of the Δabc .

Length of the hypotenuse of the $\Delta abc = 17$

- * Correct answer with no work merits full marks.
- * Indicates 17 only in diagram, or “h” or “hypotenuse”, accept for 10 marks.

Blunders (-3 marks)

B1 Gives answer as $[bc]$.

Attempts (3 marks)

A1 Any mention of a correct trigonometric ratio.

A2 Gives answer as 8 or 15.

Worthless (0)

W1 Incorrect answer with no work unless attempt mark applies.

W2 Gives more than one answer.

W3 Answer measured from examination paper.

Write down the value of $\sin B$, as a fraction.

$$\sin B = \frac{8}{17}$$

- * Correct answer with no work merits full marks.
- * Accept consistent error from part (i)
- * Accept $\sin \frac{8}{17}$ for full marks.

Blunders (-3)

- B1 Incorrect or inverted ratio e.g. $\sin B = \frac{17}{8}$.
- B2 Gets $\sin \angle acb$ (check is not consistent error from (i)).

Slips (-1)

- S1 Answer = 0.47 (answer not a fraction)

Attempts (2 marks)

- A1 Any correct trigonometric ratio written down in answer box.
- A2 Only gives answer = $28 \cdot 07^\circ$ or rounded to 28° for this part.
- A3 Only gives answer = 0.0082 i.e. $\sin \frac{8}{17}$

Worthless (0)

- W1 Incorrect answer with no work unless attempt mark applies.

Part (b)

20 marks (10, 5, 5)

Att 7 (3, 2, 2)

6(b) In the right-angled triangle pqr ,
 $|qr| = 4$, $|\angle qpr| = 48^\circ$ and $|\angle pqr| = t^\circ$.

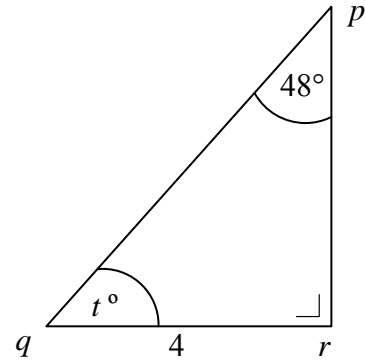

Part (b) (i)

10 marks

Att 3

(i) Find the value of t .

$$t = 180 - 90 - 48 = 42^\circ$$

* Correct answer with no work merits full marks.

Blunders (-3)

B1 Three angles of a triangle $\neq 180^\circ$

B2 Fails to subtract one of the angles e.g. $180 - 48 = 132^\circ$

B3 Mathematical error.

Slips (-1)

S1 Numerical slips to a maximum of -3.

Attempts (3 marks)

A1 Some correct step and stops e.g. 132 or 90 or 180.

A2 Writes "3 angles in a triangle add up to 180" and stops.

A3 Writes $|\angle prq| = 90^\circ$ or correctly writes the 90° angle on the diagram and stops.

A4 Any correct trigonometric ratio written down.

Worthless (0)

W1 Incorrect answer with no work unless attempt mark applies.

Using your calculator, or otherwise, write down the value of $\tan \angle pqr$ correct to one decimal place .

$$\tan \angle pqr = \tan 42 = 0.9$$

- * Correct answer with no work merits full marks.
- * Accept candidates answer from part (i).
- * Accept $\tan 0.9$ for full marks.

Blunders (-3)

B1 Writes $\tan 48 = 1.1$ or 1.11 as the answer.

B2 Finds $\sin 42$ or $\cos 42$ and continues.

B3 $\tan 42 = \frac{pr}{4}$ and stops or $\frac{pr}{4}$ on it's own.

B4 Uses Radian or Grad mode on the calculator.

	RAD	GRAD
Tan 42	2.29	0.77

Slips (-1 marks)

S1 Failure to round off or rounds off incorrectly.

Attempts (2 marks)

A1 Writes $\tan 42 = \frac{pr}{qr}$ or $\frac{pr}{qr}$ or Tan 42 and stops.

A2 Any correct trigonometric ratio written down.

A3 Correctly marks the hypotenuse or opposite or adjacent on a diagram reproduced and stops, for this part.

A4 $\cos 48 = 0.72$ $\sin 48 = 0.68$ \rightarrow Grad mode

or

$\cos 48 = -0.64$ $\sin 48 = -0.76$ \rightarrow Rad mode.

Worthless (0)

W1 Incorrect answer with no work unless attempt mark applies.

W2 0.72 or similar on its own (must be in format given in A4 to merit marks)

Hence, or otherwise, calculate $ pr $ correct to one decimal place
--



$$\begin{array}{rclclcl}
 \tan 42 & = & \frac{pr}{4} & \text{or} & 0.9 & = & \frac{pr}{4} \\
 4 \tan 42 & = & pr & & 4(0.9) & = & pr \\
 4(0.9) & = & pr & & 3.6 & = & pr \\
 3.6 & = & pr & & & &
 \end{array}$$

* Accept candidates answers from parts (i) and (ii).

Blunders (-3)

B1 Correct answer without work.

B2 Error in forming equation e.g. $\frac{4}{pr} = 1.11$ and continues

B3 Error in manipulation of equation.

B4 Writes $\frac{pr}{4} = 1.11$ and continues i.e. $\tan 48$

	RAD	GRAD
Tan 42	2.29	0.77

B5 Uses Radian or Grad mode on calculator unless already penalised in part (ii).

Slips (-1 marks)

S1 Numerical slips to a maximum of -3.

S2 Failure to round off or rounds off incorrectly.

Attempts (2 marks)

A1 Any correct step with work and stops e.g. $\frac{x}{4}$ or $\frac{4}{x}$

A2 Correct scale diagram.

A3 $\tan 42$ or 0.9 or any trigonometric ratio.

Worthless (0)

W1 Incorrect answer with no work unless attempt mark applies.

W2 Answer = 4.2cm (measured from examination paper)

Part (c)

15 marks (10, 5)

Att 5 (3, 2)

In the $\triangle abc$, $|\angle bca| = 90^\circ$, $|ab| = 25$ m and $|bc| = 24$ m.

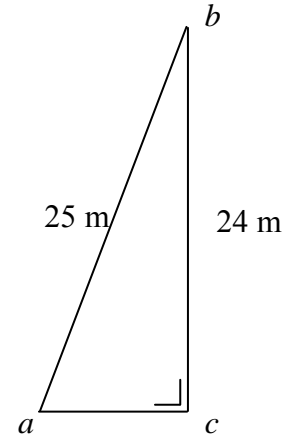

Part (c) (i)

10 Marks

Att 3

(i) Find, in metres, $|ac|$.



$$|ab|^2 = |ac|^2 + |bc|^2$$

$$|25|^2 = |ac|^2 + |24|^2$$

$$625 = |ac|^2 + 576$$

$$49 = |ac|^2$$

$$\sqrt{49} \text{ or } 7 = |ac|$$

* Accept $|ac|$ found correctly using a correct trigonometric ratio method for full marks.

Blunders (-3)

- B1 Correct answer without work
- B2 Incorrect theorem of Pythagoras and continues.
- B3 Mathematical error e.g. $24^2 = 48$
- B4 Error in manipulation of equation.
- B5 Stops at $|ac|^2 = 49$

Slips (-1 marks)

- S1 Numerical slips to a maximum of -3.

Attempts (3 marks)

- A1 Some correct step with work and stops e.g. 25^2 or writes 90° for $\angle C$ on diagram.
- A2 States theorem of Pythagoras and stops.
- A3 Correct Sin, Cos or Tan ratio written down and stops.
- A4 Labels correctly the hypotenuse e.g. $h = 25$.

Worthless (0)

- W1 Incorrect answer with no work unless attempt mark applies e.g. 625.
- W2 $25 - 24 = 1$ or $25 + 24 = 49$.
- W3 Answer = 2.4cm (measured from examination paper)



(ii) Find $|\angle bac|$, correct to the nearest degree.



$$\sin \angle bac = \frac{24}{25}$$

$$\angle bac = 73.73^\circ \text{ or } 73^\circ 44'$$

$$\angle bac = 74^\circ$$

$$\cos \angle bac = \frac{7}{25}$$

$$\angle bac = 73.73^\circ \text{ or } 73^\circ 44'$$

$$\angle bac = 74^\circ$$

* Accept candidates answer from part (i).

Blunders (-3)

- B1 Correct answer without work
- B2 Incorrect trigonometric ratio.
- B3 Decimal error.
- B4 Mathematical error.
- B5 Uses radian or grad mode on calculator.
- B6 Error in manipulation of equation.

Misreading (-1 marks)

- M1 Finds $|\angle abc|$ correctly.

Slips (-1 marks)

- S1 Numerical slips to a maximum of -3.
- S2 Fails to round off or rounds off incorrectly.
- S3 Obvious slip in reading tables or calculator.

Attempts (2 marks)

- A1 Some correct step with work and stops e.g. Sine rule stated.
- A2 Any correct trigonometric ratio written down.
- A3 Correct scale diagram.
- A4 States 180 with or without work.

Worthless (0)

- W1 Incorrect answer with no work unless attempt mark applies.